

# MANHOLE BRACE

## 32700 series

The revolutionary DCD Manhole Brace may look like other products on the market, but look again. There are several features which make it stand out from other similar products.

- Pivoting Head** - In many applications the top of the brace cannot jamb against a round manhole, instead it may be jammed against a square cutout in the roof of the manhole vault. The DCD Manhole Brace has a pivotable upper head which allows the brace and sheave to be accurately aligned with the duct bank without the need for temporary shoring / bracing.
- Custom Extruded Channels** - The aluminum channels have been custom extruded to an engineered design. Their shape provides the maximum strength-to-weight ratio while also providing a smooth sliding action. The channels have approximately twice the strength as the standard aluminum channels used in similar products, allowing a full 10,000 lb line load to be applied at either entry or exit end of the pull. This load allows in excess of a 2:1 safety factor.
- Fixed Angle** - The brace operates at a fixed angle of 10°. There is an acme screwjack assembly to adjust the height of the brace. This same screw can be used to relieve the pressure on the brace when it is being removed.
- Lifting Bar** - The lifting bar provided allows the user to easily raise the upper extension into its correct position. This bar can be swung out of the way and stored when not in use.
- Locking Pins** - The brace uses separate locking pins for each set of channels. Using two locking pins ensures that they do not interfere with the desired placement of the sheave or quadrant.
- Fixed Width** - This fixed width brace is designed to accept quadrants or sheaves up to 8" wide. Since correct alignment to the duct entrance is now possible with the rotating head, even use of only a 4" wide sheave is no problem inside the 8" available width – the sheave will simply float between the side rails always picking up the most favorable alignment.
- Construction** – Although the side channels are extruded aluminum, the upper and lower assemblies are made out of steel. While increasing the overall weight by a few pounds, the added strength of steel is necessary in order to match the strength of the extruded side channels. The end result is a Brace that can operate equally at either end of the pull and one that will match the safe working loads of all other DCD Manhole products at 10,000 lbs.

The Base Section is used in all assemblies and comes complete with 2 Locking Pins and 1 Sheave Pin. The Short, Medium or Long Extension should be ordered to suit the Height Range requirement.

Locking Pins and Sheave Pins c/w securing pins may be ordered separately.

**Note:** Replacement of any parts with components other than those supplied by DCD will void the warranty and may cause serious damage to persons or equipment.

Part No.	Description	Height Range	Weight
32700-000	Base Section	-	68 lb.
32700-010	Short Extension	5'-8'	54 lb.
32700-020	Medium Extension	7'-10'	74 lb.
32700-030	Long Extension	9'-12'	92 lb.
32700-040	Locking Pin Kit	-	1 lb.
32700-050	Sheave Pin Kit	-	4 lb.

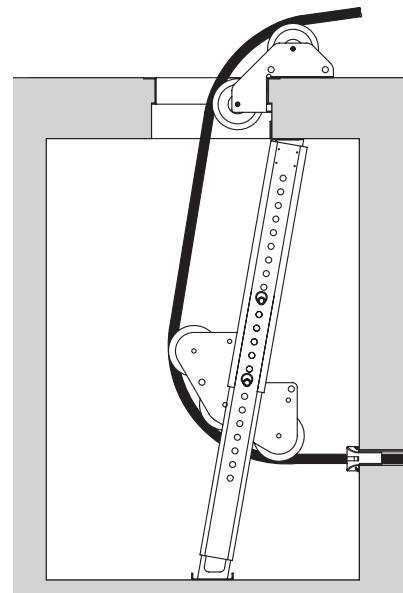

Web Site: [www.dcdesign.com](http://www.dcdesign.com)  
E-mail: [sales@dcdesign.com](mailto:sales@dcdesign.com)

Toll Free: 1-888-SWIVELS (794-8357)  
Tel: 604-232-4445  
Fax: 604-232-4446

MANHOLE TOOLS

DCD