

TUF ROD 52500 series – 1/4" Diameter

This unit is mounted in a convenient frame with carrying handle similar to, but larger than the 3/16" unit and the rod will be housed in a 24" diameter storage basket.

The end fittings will be the same as those offered with the slightly larger 5/16" rod – all Stainless Steel and with the unique DCD design allowing the fittings to be attached by either screwing or gluing onto the rod core. Thread sizes for all connections are 5/16" UNC.

Minimum bend radius is 7" and sizes available will be from 150 ft up to 600 ft. DCD does not recommend pushing lengths over 500 ft unless in relatively small ducting 2" diameter or smaller.

Standard Rodders come complete with Stainless Steel Swivel Rod End, Female Rod End and a Pulling Eye, while the Deluxe version includes accessories as listed below.

Deluxe 1/4" Rod	Rod Length	Weight	Replacement Rod	Deluxe Rod Accessories
52500-150	150 ft.	12 lb.	52600-150	
52500-200	200 ft.	13 lb.	52600-200	
52500-250	250 ft.	14 lb.	52600-250	1 Splice Connector
52500-300	300 ft.	15 lb.	52600-300	1 Flexible Guide Head
52500-350	350 ft.	16 lb.	52600-350	1 Roller Guide
52500-400	400 ft.	17 lb.	52600-400	1 Clevis End
52500-500	500 ft.	19 lb.	52600-500	1 Glue 3 gm
52500-600	600 ft.	21 lb.	52600-600	1 Rod Gripper 1 Accessory Pouch

For Standard Rodder units that do not include accessories shown above, add "X" to the part number.

Accessory Kits for the above Duct Rodders can be found on page 56.

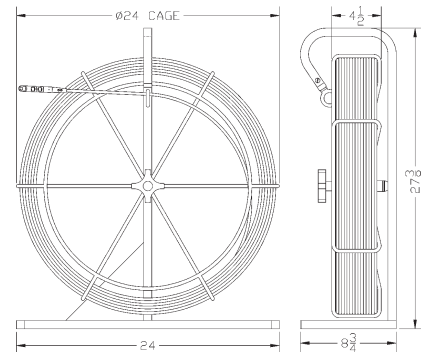

RUF ROD 53500 series – 5/16" Diameter

The 5/16" Ruf Rod is one of the most popular sizes because of its versatility in both small and medium size ducts. It is the smallest of the wheel frames, yet still well under 3 ft. in height or length so easy to store or load onto your truck.

Although DCD only recommends lengths up to 600 ft., the standard cage will hold up to 1000 ft. The longer lengths should only be used in smaller ducts (up to 2-1/2" dia) and when there are few bends.

The Standard unit includes a Female Rod End, a Swivel Rod End and a Pulling Eye. The Deluxe version includes accessories as listed below.

All accessories that attach to the rod can be glued on in the traditional manner or they can be clamped on with set screws or they can be glued and screwed for extra security.

Deluxe 5/16" Rod	Deluxe Detectable	Rod Length	Weight	Replacement Reg. Rod	Deluxe Rod Accessories
53500-200	53700-200	200 ft.	32 lb.	53600-200	
53500-250	53700-250	250 ft.	34 lb.	53600-250	
53500-300	53700-300	300 ft.	36 lb.	53600-300	
53500-350	53700-350	350 ft.	38 lb.	53600-350	1 Splice Connector
53500-400	53700-400	400 ft.	40 lb.	53600-400	1 Flexible Guide Head
53500-500	53700-500	500 ft.	44 lb.	53600-500	1 Roller Guide
53500-600	53700-600	600 ft.	48 lb.	53600-600	1 Clevis End
53500-700	53700-700	700 ft.	52 lb.	53600-700	1 Glue 3 gm
53500-800	53700-800	800 ft.	56 lb.	53600-800	1 Rod Gripper
53500-900*	53700-900*	900 ft.	60 lb.	53600-900	1 Accessory Pouch
53500-1000*	53700-1000*	1000 ft.	64 lb.	53600-1000	

* These two sizes are spooled on a 3/8" (54000) frame, see 54000 Specs for frame dimensions.

For Standard Rodder units that do not include accessories shown above, add "X" to the part number.

Accessory Kits for the above Duct Rodders can be found on page 56. For Detectable Duct Rodder information see page 55.

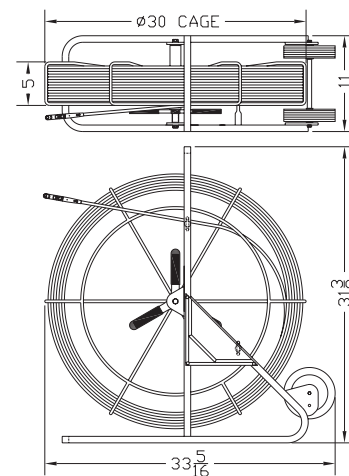

Web Site: www.dcdesign.com
E-mail: sales@dcdesign.com

Toll Free: 1-888-SWIVELS (794-8357)
Tel: 604-232-4445
Fax: 604-232-4446

DUCT RODDERS & ACCESSORIES

EXTREME DANGER: NEVER USE THIS DETECTABLE RODDER IN A LIVE ELECTRICAL ENVIRONMENT. ELECTRICAL SHOCK OR DEATH MAY RESULT IF CONDUCTIVE ROD TOUCHES EXPOSED CIRCUIT.

