

# OPERATING SPECIFICATIONS

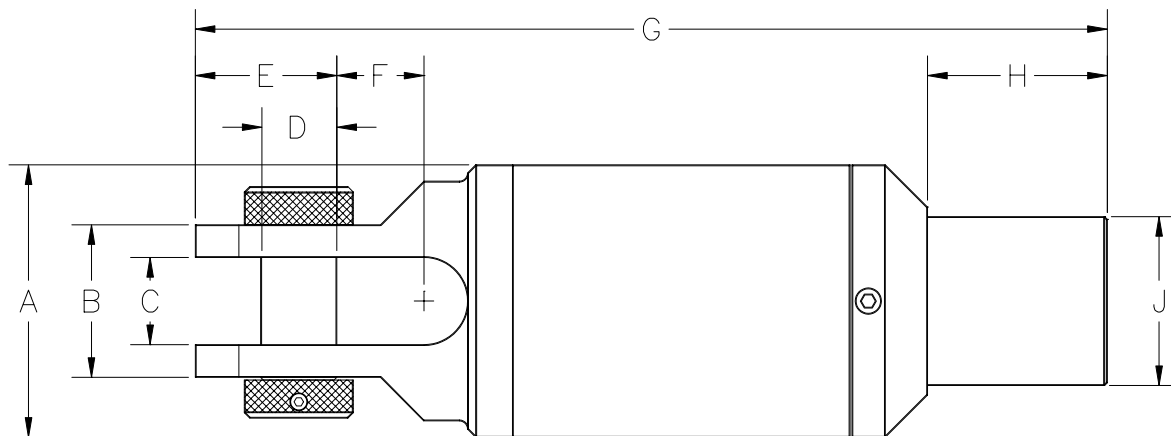

## SERIES 00508 MAXI DUB-SWIVEL<sup>®</sup> STYLE 1

1. The MAXI DUB Swivel<sup>®</sup> is specifically designed for directional drilling applications. It is intended for coupling the reamer head to the utility being pulled back. The swivel permits rotation of the drill pipe while protecting the utility from twisting.
2. The style 1 swivel has a clevis located on one end and an API box connection on the other.



Part Number	Safe Working Limit	Ultimate Load	Box Thread	A	B	C	D	E	F	G	H	J	Net Weight
00508-1110	110 TON 100 TONNE	400 TON 360 TONNE	4-1/2 IF API	10-3/4 275	6 150	3-1/4 83	2-1/2 63	4-3/4 121	2-3/4 70	35 889	7-1/2 191	6-5/8 168	420 lb 190 kg
00508-1165	165 TON 150 TONNE	600 TON 540 TONNE	4-1/2 IF API	10-3/4 275	6-1/2 165	3-1/2 89	3 76	5-1/2 140	3 76	38 965	7-1/2 191	6-5/8 168	580 lb 260 kg
00508-1220	220 TON 200 TONNE	750 TON 680 TONNE	6-5/8 REG API	12-1/2 320	7 178	4 102	3-1/2 89	6-1/2 165	4 102	42 1070	8-1/4 210	7-3/4 197	860 lb 390 kg
00508-1350	350 TON 320 TONNE	1250 TON 1130 TONNE	7-5/8 REG API	16 405	9 229	5 127	4-1/2 114	8-1/2 216	4-1/2 114	50-3/4 1290	9-1/2 241	9-1/4 235	1,690 lb 770 kg
00508-1351	350 TON 320 TONNE	1250 TON 1130 TONNE	6-5/8 FH API	16 405	9 229	5 127	4-1/2 114	8-1/2 216	4-1/2 114	50-11/16 1287	8-7/8 225	8-1/2 216	1,690 lb 770 kg
00508-1500	500 TON 450 TONNE	1750 TON 1580 TONNE	7-5/8 REG API	19-1/2 495	10-1/2 267	5-1/2 140	5-1/2 140	9-3/4 248	5-1/4 133	55-1/2 1410	9-1/2 241	9-1/4 235	2,700 lb 1,230 kg
00508-1700	700 TON 640 TONNE	2500 TON 2270 TONNE	7-5/8 REG API	23 585	12 305	6-1/2 165	6-1/2 165	11-1/4 285	5-3/4 140	65-1/2 1660	9-1/2 241	9-1/4 235	4,120 lb 1,880 kg

Dimensions and weights subject to change without notice.

**Bold** linear dimensions in inches, non-bold in millimeters.

The **Ultimate Load** is the tensile loading required to separate the DUB Swivel<sup>®</sup> into two or more parts.

# OPERATING INSTRUCTIONS

# DCD

## Design & Manufacturing Ltd.

### SERIES 00508 MAXI DUB-Swivel® STYLE 1



## OPERATION

1. Thread the swivel onto the reamer and torque to the requirements of the API thread specification.
2. Remove the socket head cap screw and lock washer from the clevis pin nut.
3. Unscrew the clevis pin nut from the clevis pin and remove the clevis pin from the swivel.
4. Insert the items you want to attach into the clevis end. Re assemble the clevis pin and nut.

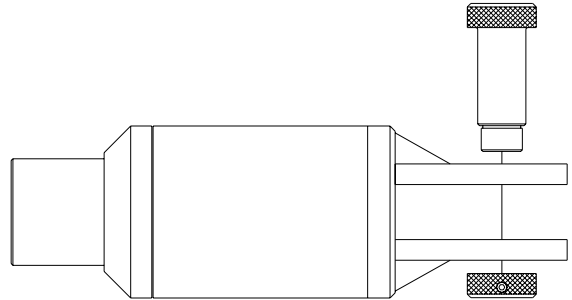

## SAFETY

The MAXI DUB-Swivel® is designed to operate only within its specified safe working limit (see *Operating Specifications*). Operation of the MAXI DUB-Swivel® at loads in excess of its **safe working limit** will void the warranty as that may cause permanent bearing damage even though separation due to failure will not occur until the specified **ultimate load** is reached.



**Rotating parts can cause death or serious injury!** Stay well clear. Do not wear loose clothing.



**A swivel is not a universal joint!** It is designed to be used under tension and in a straight line. Any use of this product that allows the swivel to fall away from the centerline of rotation will severely affect the life of the swivel.



**Make sure that all components of the pulling system are able to withstand the maximum pulling loads.** Components not rated for the pull force may break and release the stored energy of the pull. Never use a worn, defective or incomplete component.



**Be prepared for the unexpected.** Always use recognized safety practices and wear recognized safety equipment.



**Replace worn or damaged clevis pins with only DCD parts.** The Clevis Pin is designed specifically for this application. It is manufactured and heat treated in a manner to satisfy both design requirements and claimed capacities. Use of any other product as a replacement part will void the warranty and may result in property damage, severe bodily harm, or death to operators or persons nearby. In any instances, the DCD warranty will be voided and DCD will accept no responsibility for product failure or personal injury.



**Do not modify or dismantle the MAXI DUB-Swivel®.** It has been assembled, and inspected and is only covered by a warranty in its "as shipped" form. Any attempt to dismantle or modify the swivel will result in the warranty becoming void.

# OPERATING INSTRUCTIONS

## SERVICE



While the machine is still rotating, use a water hose to wash all dirt from the split line groove. Pour oil into the groove and rotate the swivel a couple of turns to protect the mechanical seal from drying out. Failure to do so will allow mud to dry inside the cavity above the seals, which may damage the rubber portion of the seals.



Assess the condition of the swivel checking for wear and external damage. Check for axial and radial play in the bearings. Replace worn or bent clevis pins.



Lubricate the swivel with a **lithium-based grease** containing an extreme pressure (EP) additive (the swivel has been factory lubricated with **Renolit S2TX** grease). Do not mix with calcium or other based greases.

1. Remove the pipe plug located in the bottom of the clevis on the swivel cap.
2. Remove the 2 pipe plugs located on the front face of the seal cover.
3. Use a hand operated grease gun with slow pumping action.
4. Check to make sure relief valve is not plugged.



**Do not remove the relief valves or replace with an additional grease nipple! Lack of proper lubrication will shorten life of the bearings.**



The seals on these swivels may be inspected and replaced in the field by removal of the seal cover. A replacement seal kit is available. Each kit contains a mechanical seal, lip seal, extractor tool, and a set of instructions for removing and replacing the seals.



Factory rebuild services are available for the MAXI DUB-Swivel®. With this service we will replace bearings, seals, and any other worn parts, as well as offer a conditional continuation on our warranty. Assembly of this product is complex and we strongly recommend use of this service. For re-build information call the factory toll free at **1-888-794-8357**.

