

OPERATING SPECIFICATIONS

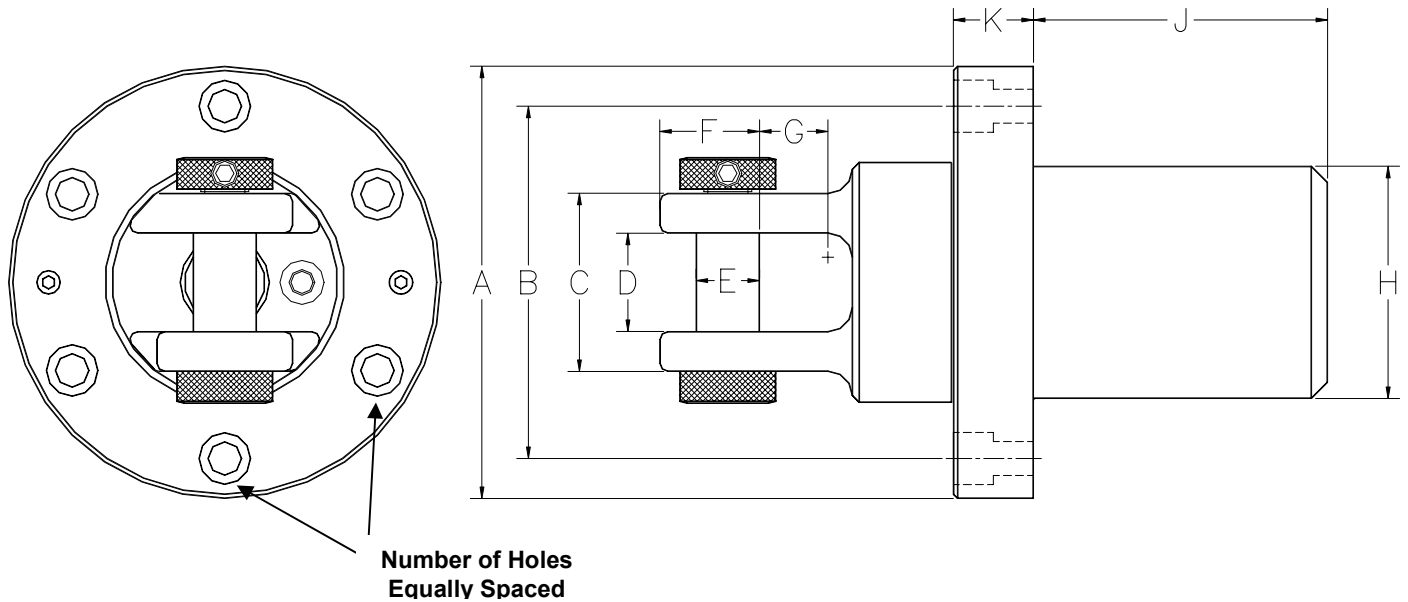

SERIES 00508 DUB SWIVEL[®] STYLE 6

- The DUB Swivel[®] is specifically designed for directional drilling applications. It is intended to be mounted internally in a backreamer using a bolt flange. The swivel permits rotation of the drill pipe while protecting the utility from twisting.



Part Number	Safe Working Limit	Ultimate Load	A	B	C	D	E	F	G	H	J	K	Number of Holes	Flange Bolt	Net Weight
00508-605	10,000 lb 44 kN	50,000 lb 222 kN	5" 127 mm	4" 101.6 mm	2-1/4" 57 mm	1-1/4" 32 mm	3/4" 19 mm	1-5/16" 33 mm	7/8" 22 mm	2-7/8" 73 mm	3-11/16" 94 mm	1-1/16" 27 mm	6	3/8 UNC	15 lb 6.8 kg
00508-610	20,000 lb 89 kN	100,000 lb 445 kN	6-1/8" 159 mm	4-7/8" 123.8 mm	2-3/4" 70 mm	1-1/2" 38 mm	1" 25 mm	1-5/8" 41 mm	15/16" 24 mm	3-5/8" 92 mm	4-5/8" 117 mm	1-3/8" 35 mm	6	1/2 UNC	29 lb 12 kg
00508-615	30,000 lb 133 kN	150,000 lb 667 kN	7-1/4" 184 mm	5-7/8" 149.2 mm	3-1/4" 83 mm	1-3/4" 44 mm	1-1/8" 29 mm	2-1/16" 52 mm	1-7/16" 36 mm	4-3/8" 111 mm	5-7/8" 149 mm	1-1/2" 38 mm	6	5/8 UNC	51 lb 26 kg
00508-620	40,000 lb 178 kN	200,000 lb 890 kN	9-1/2" 241 mm	7-3/4" 196.8 mm	3-1/2" 89 mm	1-3/4" 44 mm	1-3/8" 35 mm	2-1/2" 63 mm	1-7/16" 36 mm	6" 152 mm	6-1/16" 149 mm	2" 51 mm	8	3/4 UNC	57 lb 25.9 kg
00508-630	60,000 lb 267 kN	300,000 lb 1330 kN	9-1/2" 241 mm	7-3/4" 196.8 mm	3-1/2" 89 mm	1-3/4" 44 mm	1-3/8" 35 mm	2-1/2" 63 mm	1-7/16" 36 mm	6" 152 mm	6-1/16" 154 mm	2" 51 mm	8	3/4 UNC	83 lb 37.7 kg
00508-640	80,000 lb 356 kN	400,000 lb 1780 kN	9-1/2" 241 mm	7-3/4" 196.8 mm	4-5/8" 117 mm	2-1/8" 54 mm	1-3/4" 44 mm	3-5/16" 84 mm	1-7/8" 48 mm	6" 152 mm	8" 204 mm	2" 51 mm	8	3/4 UNC	157 lb 71 kg

Dimensions and weights subject to change without notice.

The **Safe Working Limit** is calculated using a 5:1 safety factor based on the ultimate load.

The **Ultimate Load** is the tensile loading required to separate the DUB Swivel[®] into two or more parts.

OPERATING INSTRUCTIONS

DCD Design & Manufacturing Ltd. SERIES 00508 DUB SWIVEL[®] STYLE 6



INSTALLATION

1. Back off the jacking screws in the flange so that they do not protrude from the mating side of the flange.
2. Insert the swivel assembly into the bore of the reamer and align the bolt holes in the flange. Attach the swivel using the socket head capscrews.
3. Tighten the jacking screws down against the reamer to prevent them from vibrating loose. Note: where very high vibration bores are anticipated Loctite may be used to further secure the six socket head capscrews.
4. To remove the swivel, remove the six socket head capscrews. Use the jacking screws to break the joint between the flange and the reamer.

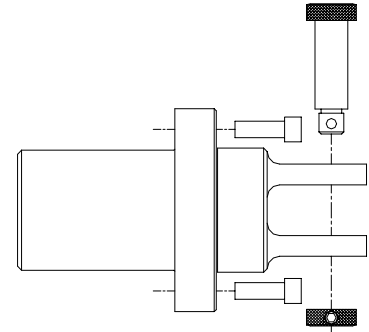

SAFETY

The DUB-Swivel[®] is designed to operate only within its specified safe working limit (see *Operating Specifications*). Operation of the DUB Swivel[®] at loads in excess of its **safe working limit** will void the warranty as that may cause permanent bearing damage even though separation due to failure will not occur until the specified **ultimate load** is reached.



Rotating parts can cause death or serious injury! Stay well clear. Do not wear loose clothing.



Make sure that all components of the pulling system are able to withstand the maximum pulling loads. Components not rated for the pull force may break and release the stored energy of the pull. Never use a worn, defective or incomplete component.



Be prepared for the unexpected. Always use recognized safety practices and wear recognized safety equipment.



Do not modify or dismantle the DUB-Swivel[®]. It has been assembled, and inspected and is only covered by a warranty in its "as shipped" form. Any attempt to dismantle or modify the swivel will result in the warranty becoming void.



Replace worn or damaged clevis pins and nuts with only DCD parts. The Clevis Pin is designed specifically for this application. It is manufactured and heat treated in a manner to satisfy both design requirements and claimed capacities. Use of any other product as a replacement part will void the warranty and may result in property damage, severe bodily harm, or death to operators or persons nearby. In any instances, the DCD warranty will be voided and DCD will accept no responsibility for product failure or personal injury.

SERVICE



After each use, while the machine is still rotating, use a water hose to wash all dirt from the split line groove. Pour oil into the groove and rotate the swivel a couple of turns to protect the mechanical seal from drying out. Failure to do so will allow mud to dry inside the cavity above the seals, which may damage the rubber portion of the seals.



Assess the condition of the swivel checking for wear and external damage. Check for axial and radial play in the bearings. Replace worn or bent clevis pins.



Lubricate the swivel with a **lithium-based grease** containing an extreme pressure (EP) additive. The swivel has been factory lubricated with **Renolit S2TX** grease. Do not mix with calcium or other based greases. Use a hand-operated grease gun with slow pumping action and check to make sure relief valve is not plugged. **Do not remove the relief valve or replace with an additional grease nipple!** Lack of proper lubrication will shorten the life of the bearings.



A replacement part kit is available for the DUB-Swivel® clevis pins. Each kit contains (2) clevis pins, (2) clevis pin nuts, (2) lockwashers and (2) capscrews. The kit part number is 00508-0XX. For other spare parts, contact your dealer for price and availability. Never use standard HEX Bolts as replacement for the DCD Clevis Pins.



Factory rebuild services are available for the DUB-Swivel®. With this service we will replace bearings, seals, and any other worn parts, as well as offer a conditional continuation on our warranty. Assembly of this product is complex and we strongly recommend use of this service. For re-build information call the factory toll free at **1-888-794-8357**.

