

OPERATING SPECIFICATIONS

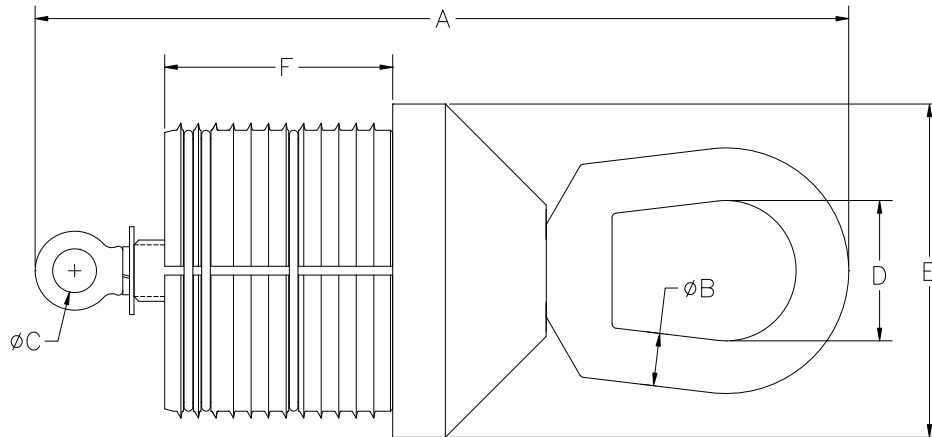

SERIES 00620 DUCT PULLER (Imperial Sizes)

1. Series 00620 Duct Pullers are designed for pulling non-metallic duct, utilizing adjustable expanding jaws.



Part Number	Safe Working Limit	Nominal Duct Diameter	A	B	C	D	E	F	Net Weight
00620-125	3,750 lb 16.6 kN	1-1/4"	7-1/16"	3/8"	3/8"	1-1/4"	2"	9 Teeth 2"	1.6 lb 0.73 kg
00620-150	3,750 lb 16.6 kN	1-1/2"	7-1/16"	3/8"	3/8"	1-1/4"	2"	9 Teeth 2"	1.7 lb 0.77 kg
00620-200	6,000 lb 26.6 kN	2"	8-5/16"	1/2"	1/2"	1-1/2"	2-1/2"	10 Teeth 2-1/2"	3.0 lb 1.36 kg
00620-250	6,000 lb 26.6 kN	2-1/2"	9-3/16"	1/2"	1/2"	1-1/2"	3"	10 Teeth 2-1/2"	4.9 lb 2.2 kg
00620-300	12,000 lb 53.3 kN	3"	13-3/16"	3/4"	3/4"	2"	3-3/4"	11 Teeth 3"	8.9 lb 4.0 kg
00620-400	12,000 lb 53.3 kN	4"	13-13/16"	3/4"	3/4"	2"	4-3/4"	12 Teeth 3-1/4"	14.5 lb 6.6 kg
00620-500	25,500 lb 113.4 kN	5"	16-3/16"	1"	1"	2-1/2"	6"	17 Teeth 4-1/2"	31.5 lb 14.3 kg
00620-600	25,500 lb 113.4 kN	6"	18"	1"	1"	2-1/2"	7"	21 Teeth 5-1/2"	48.6 lb 22.0 kg
00620-800	37,000 lb 164.5 kN	8"	19-1/2"	1"	1-1/2"	2-1/2"	8-3/4"	19 Teeth 6"	90 lb 40.8 kg
00620-1009	79,000 lb 351.4 kN	10" SDR 9	20-15/16"	1-1/4"	1-1/2"	3-1/8"	10-5/8"	19 Teeth 6"	135 lb 61.2 kg
00620-1011	79,000 lb 351.4 kN	10" SDR 11	20-15/16"	1-1/4"	1-1/2"	3-1/8"	10-5/8"	19 Teeth 6"	135 lb 61.2 kg
00620-1017	79,000 lb 351.4 kN	10" SDR 17	20-15/16"	1-1/4"	1-1/2"	3-1/8"	10-5/8"	19 Teeth 6"	135 lb 61.2 kg
00620-1209	125,000 lb 556 kN	12" SDR 9	23-7/8"	1-1/2"	1-1/2"	4"	12-3/4"	19 Teeth 6"	190 lb 86.2 kg
00620-1211	125,000 lb 556 kN	12" SDR 11	23-7/8"	1-1/2"	1-1/2"	4"	12-3/4"	19 Teeth 6"	190 lb 86.2 kg
00620-1217	125,000 lb 556 kN	12" SDR 17	23-7/8"	1-1/2"	1-1/2"	4"	12-3/4"	19 Teeth 6"	190 lb 86.2 kg

The **Safe Working Limit** of the puller is calculated using a 3:1 safety factor based on the ultimate load. Operation of the puller at loads in excess of its **Safe Working Limit** may cause permanent damage and the warranty will be voided. Dimensions and weights subject to change without notice.

OPERATING INSTRUCTIONS



**Design &
Manufacturing Ltd.**

SERIES 00620 DUCT PULLER



SELECTION

1. Use the following table when selecting a puller to fit the duct.
2. Refer to the following table for replacement "O"-rings for jaws.
3. The Series 00620 Duct Puller is made up of five basic components, as shown on the drawing. The eye nut, when tightened, draws the mandrel into the jaws seating the jaws into the duct.
4. Item (6) "Duct Plugger" is used to keep drilling mud and fluids from entering the duct when pulling it into place. This product must be ordered separately from the Duct Puller.
5. Item (7) "Duct Sleeve" is used to contain thin wall ducting when the Duct Puller is expanded, thus giving the expanding shells a firmer grip on the duct. This product must be ordered separately from the Duct Puller and is highly recommended when pulling thin wall PE ducting or PVC.

1. Face Plate
2. Jaws
3. Mandrel (hidden)
4. Eye Nut
5. Eye Bolt
6. Duct Plugger
7. Duct Sleeve

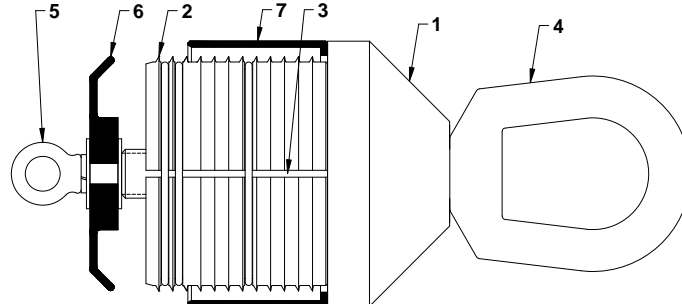

Duct Puller Part#	Nominal Duct Diameter	Minimum Duct Inside Dia.	Maximum Duct Inside Dia.	Duct Sleeve Part#	Duct Plugger Part#	Replacement Jaw "O"-Ring Qty & Part#
00620-125	1-1/4"	1-9/32"	1-1/2"	00625-125	00630-125	2 x 90027-100
00620-150	1-1/2"	1-15/32"	1-11/16"	00625-150	00630-150	2 x 90027-100
00620-200	2"	1-7/8"	2-1/8"	00625-200	00630-200	2 x 90027-175
00620-250	2-1/2"	2-1/4"	2-1/2"	00625-250	00630-250	2 x 90027-213
00620-300	3"	2-3/4"	3-1/16"	00625-300	00630-300	2 x 90027-250
00620-400	4"	3-1/2"	4-1/16"	00625-400	00630-400	3 x 90027-250
00620-500	5"	4-1/2"	5"	N/A	00630-500	4 x 90027-400
00620-600	6"	5-7/16"	6-1/8"	N/A	00630-600	4 x 90027-475
00620-800	8"	6-7/16"	7-7/8"	N/A	00630-800	3 x 90027-5001
00620-1009	10" SDR 9	7-15/16"	8-5/8"	N/A	N/A	3 x 90027-6001
00620-1011	10" SDR 11	8-3/8"	9-1/16"	N/A	N/A	3 x 90027-6001
00620-1017	10" SDR 17	9-1/16"	9-3/4"	N/A	N/A	3 x 90027-6001
00620-1209	12" SDR 9	9-9/16"	10-1/4"	N/A	N/A	5 x 90027-7381
00620-1211	12" SDR 11	10-1/16"	10-3/4"	N/A	N/A	5 x 90027-7381
00620-1217	12" SDR 17	10-15/16"	11-9/16"	N/A	N/A	5 x 90027-7381

OPERATING INSTRUCTIONS



**Design &
Manufacturing Ltd.**

SERIES 00620 DUCT PULLER



INSTALLATION

1. To install the Duct Puller, make sure to first collapse the jaws. To do this, grip the face plate while turning the eye nut in a counter clockwise direction. The mandrel should come out as far as the stop washer, allowing the jaws to fully collapse.

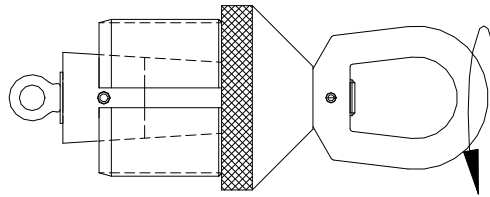

2. Attach pull tape to the eyebolt if desired, insert the Duct Puller into the duct up to the face plate. Note: the eyebolt is not rated to the same SWL as the puller. Turn the eye nut in a clockwise rotation while gripping the face plate until firm contact is felt.

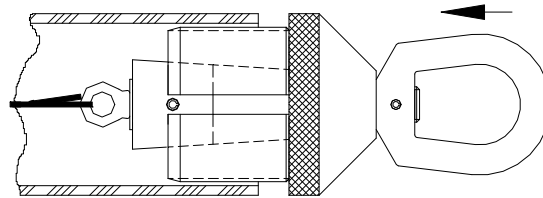

3. Grip the duct firmly and using a leverage bar, tighten the eye nut until it advances approximately the number of rotations shown in the table below. This will depend on the type of duct being installed. During installation, the ducting should be prevented from stretching by using a Duct Sleeve or other form of restraint.

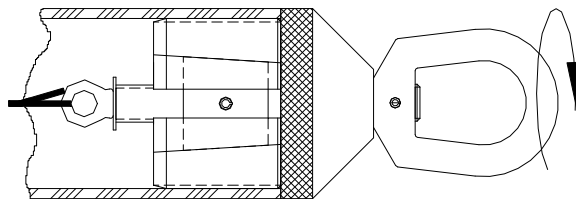

WARNING: There is a limit to the travel of the mandrel. When a solid feel is encountered during tightening, this limit may have been reached. Do not attempt to over tighten as this may cause damage to the Duct Puller.

DUCT WALL	SDR 11	SDR 13	SDR 15	SDR 17
NUMBER OF FULL TURNS AFTER CONTACT	6-8 TURNS	5-7 TURNS	4-6 TURNS	3-5 TURNS

4. To remove, loosen off the eye nut in a counter clockwise rotation using a leverage bar. NOTE: It may be necessary to lightly hammer on the outside of the duct to loosen the grip of the jaws.

OPERATING INSTRUCTIONS

DCD Design & Manufacturing Ltd.

SERIES 00620 DUCT PULLER



OPERATION



1. This product **must not** be used if the pulling mechanism functions in a **counter clockwise rotation**. This will cause the Duct Puller to loosen its grip within the duct.
2. A swivel must **always** be used between the Duct Puller and the pulling mechanism to avoid severe damage to the duct and the Duct Puller as well as extreme likelihood of personal injury.

SAFETY



1. Certain factors may cause the pull to separate and release the stored energy of the duct, rope, chain or cable. Make sure that all components of the pulling system are able to withstand the maximum pulling loads. Components not rated for the pull force may break and release the stored energy of the pull. Never use a worn, defective or incomplete component.

2. Be prepared for the unexpected. Use recognized safety practices and wear recognized safety equipment.

SERVICE



1. To maintain this product in the best possible condition, a light smear of grease should be applied to the surface of the taper on the mandrel and the thread it rides on after each use.
2. Apply grease or graphite based oil to the thrust washer below the head of the eye nut.