

# OPERATING, SAFETY AND SERVICE INSTRUCTION MANUAL

**DCD** Design & Manufacturing Ltd.

Series 00651 Dub-Wise™

Duct Puller / Metric Series

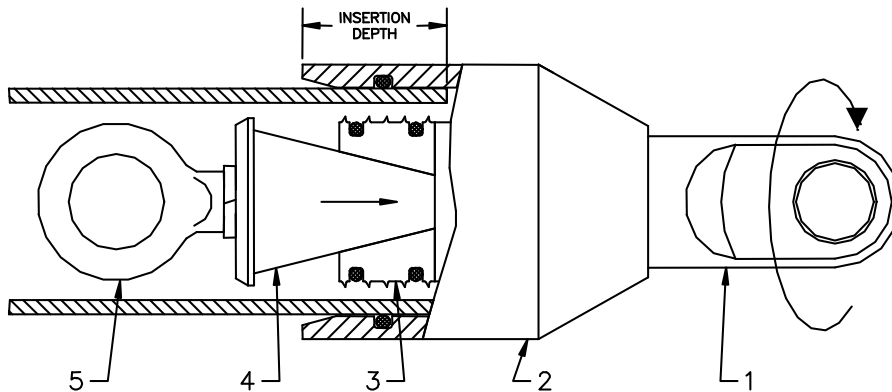

Series 00651 Dub-Wise™ Pullers are designed for pulling non-metallic duct. The Dub-Wise™ pulls, seals (tested to over 60 p.s.i.), and prevents the duct from stretching utilizing the outer body. This design also features a full size rear eye nut for back loads.

1. HEAD
2. BODY
3. JAWS
4. MANDREL
5. TAILPIECE

## SELECTION / INSTALLATION

1. Collapse the expanding jaws by gripping the body of the puller and turn the head in a counter clockwise direction until the mandrel reaches the end of its travel, then turn the head one turn clockwise.
2. Attach pull tape to the tailpiece eye bolt if desired.
3. Determine the **Insertion Depth** from the following table and insert the puller into the pipe a distance equal or greater than this depth. Tap the head with a hammer if necessary.
4. Grip the body of the puller and turn the head in a clockwise direction using a wrench until you feel the jaws make contact with the inside diameter of the pipe.
5. Consult the table below to determine the **number of turns** to full engagement. Turn the head this **additional** number of turns. The puller is now ready for use.
6. To remove the puller, grip the body and turn the head counter clockwise until the mandrel reaches the end of its travel, **DO NOT FORCE IT ANY FURTHER**. Remove the puller from the pipe. If the jaws have not disengaged, tap lightly with a hammer on the outside of the pipe.

Dub-Wise™ Duct Puller Part Number	Nominal Duct Diameter	Net Weight
00651-040	40 mm	2.15 lb 0.98 kg
00651-050	50 mm	2.5 lb. 1.13 kg
00651-063	63 mm	5.25 lb 2.38 kg
00651-075	75 mm	6.21 lb 2.82 kg
00651-090	90 mm	9 lb 4.1 kg
00651-110	110 mm	24 lb 10.9 kg
00651-125	125 mm	28.5 lb 12.93 kg
00651-140	140 mm	37.5 lb 17.0 kg
00651-160	160 mm	64 lb 29.0 kg



## OPERATION



1. Polyethylene ducting is subject to creep failure at stress levels well below its yield strength. The following table contains recommended maximum loads that are based on 40% of the yield strength of polyethylene pipe conforming to ASTM D1248 Grade P34. Exceeding these values may cause permanent deformation to the pipe. These values may vary depending on the properties of your specific pipe. For values applicable to your pipe, consult the pipe manufacturer.
2. **DO NOT USE THIS PRODUCT WITH STEEL PIPE.**
3. This product **must not** be used if the pulling mechanism functions in a **counter clockwise rotation**. This will cause the Dub-Wise™ puller to loosen its grip within the duct.
4. A swivel must **always** be used between the Dub-Wise™ puller and the pulling mechanism to avoid severe damage to the duct and the Dub-Wise™ puller as well as extreme likelihood of personal injury.

Nominal Duct Diameter	Dub-Wise™ Part Number	Safe $\Phi$ Working Limit	Maximum Recommended Load for Polyethylene Pipe				
			PN 20	PN 16	PN 13	PN 10	PN 6
40 mm	00651-040	3100 lb 13.8 kN	984 lb 4.3 kN	824 lb 3.6 kN	684 lb 3.0 kN	552 lb 2.4 kN	348 lb 1.5 kN
50 mm	00651-050	3600 lb 16.0 kN	1540 lb 6.8 kN	1288 lb 5.7 kN	1068 lb 4.7 kN	864 lb 3.8 kN	544 lb 2.4 kN
63 mm	00651-063	5600 lb 24.9 kN	2444 lb 10.8 kN	2044 lb 9.0 kN	1696 lb 7.5 kN	1368 lb 6.0 kN	864 lb 3.8 kN
75 mm	00651-075	8200 lb 36.5 kN	3464 lb 15.4 kN	2896 lb 12.8 kN	2404 lb 10.6 kN	1940 lb 8.6 kN	1224 lb 5.4 kN
90 mm	00651-090	12200 lb 54.3 kN	5000 lb 22.2 kN	4160 lb 18.5 kN	3440 lb 15.3 kN	2796 lb 12.4 kN	1764 lb 7.8 kN
110 mm	00651-110	20100 lb 89.4 kN	7440 lb 33.0 kN	6240 lb 27.7 kN	5160 lb 22.9 kN	4160 lb 18.5 kN	2632 lb 11.7 kN
125 mm	00651-125	24700 lb 110.0 kN	9600 lb 42.7 kN	8040 lb 35.7 kN	6680 lb 29.7 kN	5400 lb 24.0 kN	3400 lb 15.1 kN
140 mm	00651-140	30700 lb 136.6 kN	12080 lb 53.7 kN	10080 lb 44.8 kN	8360 lb 37.1 kN	6760 lb 30.0 kN	4280 lb 19.0 kN
160 mm	00651-160	43600 lb 193.9 kN	15760 lb 70.1 kN	13200 lb 58.7 kN	10960 lb 48.7 kN	8840 lb 39.3 kN	5560 lb 24.7 kN

①The **Safe Working Limit** of the puller is calculated using a 3:1 safety factor based on the ultimate load.

②The **Ultimate Load** is the tensile loading required to separate the puller into two or more parts.

Operation of the puller at loads in excess of its **Safe Working Limit** may cause permanent damage and the warranty will be voided.

## SAFETY



1. Certain factors may cause the pull to separate and release the stored energy of the duct, rope, chain or cable. Make sure that all components of the pulling system are able to withstand the maximum pulling loads. Components not rated for the pull force may break and release the stored energy of the pull. Never use a worn, defective or incomplete component.

2. Be prepared for the unexpected. Always use recognized safety practices and wear recognized safety equipment.

## SERVICE



1. To maintain this product in the best possible condition, a light smear of grease should be applied to the surface of the taper on the mandrel and the thread it rides on after each use.