

OPERATING SPECIFICATIONS

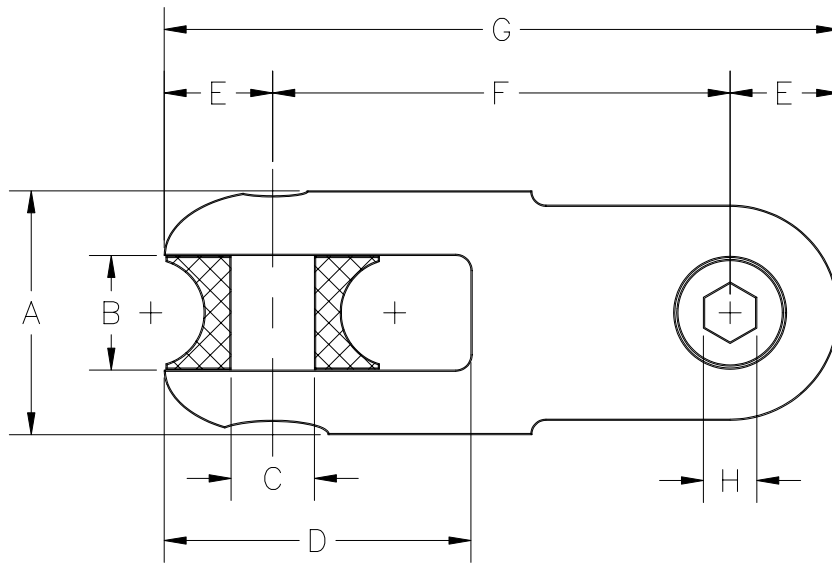

SERIES 00521 ROPE TO ROPE CONNECTOR

1. The connector is intended for coupling any combination of pulling ropes, flexible head pulling grips, or rotating head pulling grips.



Part Number	Underground Safe Working Limit	Overhead Safe Working Limit	Ultimate Load	A	B	C	D	E	F	G	H	Net Weight
00521-035	15,000 lb 67 kN	9,000 lb 40 kN	45,000 lb 200 kN	2" 51 mm	15/16" 23.8 mm	11/16" 17.5 mm	2-1/2" 63.5 mm	7/8" 22.2 mm	3-3/4" 96 mm	5-1/2" 140 mm	7/16"	2.7 lb 1.2 kg

Dimensions and weights subject to change without notice.

The **Underground Safe Working Limit** is calculated using a 3:1 safety factor based on the ultimate load.

The **Overhead Safe Working Limit** is calculated using a 5:1 safety factor based on the ultimate load.

The **Ultimate Load** is the tensile load required to separate the connector into two or more parts.

OPERATING INSTRUCTIONS

DCD Design & Manufacturing Ltd.

SERIES 00521 CONNECTOR



INSTALLATION

1. Remove the clevis pins and sheaves from the connector.

2. Insert the rope eyes into the sheaves. Reassemble the sheaves and clevis pins into the connector.

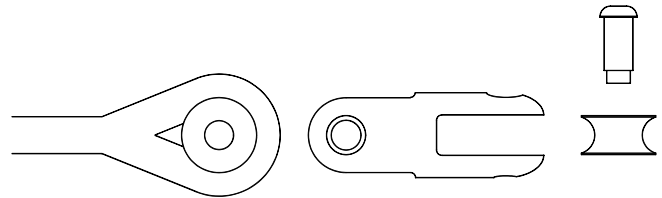

SAFETY



1. The connector is designed to operate only within its specified **safe working limit** (see *Operating Specifications*). Operation of the connector at loads in excess of its **safe working limit** will void the warranty even though separation due to failure will not occur until the specified **ultimate load** is reached.

2. For underground use, the recommended safe working limit is 3:1 based on the ultimate load. For overhead use, the required safe working limit is 5:1 based on the ultimate load due to the higher risk of severe personal injury or property damage.

3. Never use a worn, defective or incomplete component. Ensure that all components of the pulling system are able to withstand the maximum pulling loads. Components not rated for the pull force may break and release the stored energy of the pull.

4. Do not modify the connector. It is only covered by a warranty in its “as shipped” form. Any attempt to modify the connector will void the warranty and may result in property damage, severe bodily harm, or death.

5. Be prepared for the unexpected. Use recognized safety practices and wear recognized safety equipment.

SERVICE



1. After each use, examine the condition of the connector. Replace worn or bent clevis pins with original equipment manufacturer's pins.

2. Replacement pins and sheave are available as spare parts.