

# OPERATING SPECIFICATIONS



**Design &  
Manufacturing Ltd.**

## SERIES 54000 RUF ROD

1. The duct rodder is intended for feeding through existing ductwork and pulling back a pull tape or pull rope.

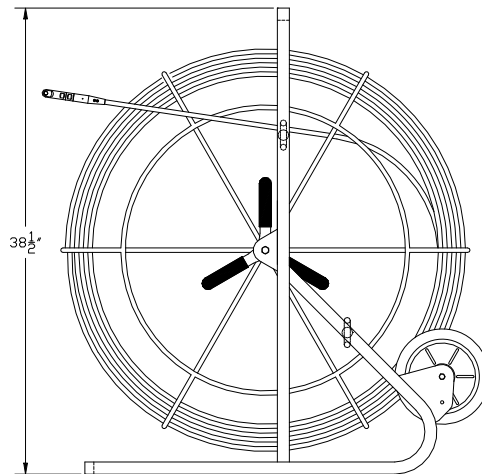
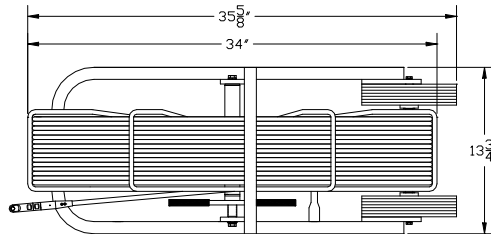

Part Number	Rod Length	Rod Diameter	Core Diameter	Min Bend Radius	Accessory Thread	Net Weight
54000-200	200 ft	0.350"	0.240"	12"	3/8"-16	47 lb 21 kg
54000-300	300ft	0.350"	0.240"	12"	3/8"-16	53 lb 24 kg
54000-400	400 ft	0.350"	0.240"	12"	3/8"-16	59 lb 27 kg
54000-500	500 ft	0.350"	0.240"	12"	3/8"-16	67 lb 30.4 kg
54000-600	600 ft	0.350"	0.240"	12"	3/8"-16	71 lb 32 kg
54000-700	700 ft	0.350"	0.240"	12"	3/8"-16	77 lb 35 kg
54000-800	800 ft	0.350"	0.240"	12"	3/8"-16	83 lb 37.6 kg
54000-900	900 ft	0.350"	0.240"	12"	3/8"-16	89 lb 40 kg
54000-1000	1,000 ft	0.350"	0.240"	12"	3/8"-16	95 lb 43 kg

Dimensions and weights subject to change without notice.

For Standard Rodder units that do not include accessories, add "X" to the part number.

# OPERATING INSTRUCTIONS



**Design &  
Manufacturing Ltd.**

**SERIES 54000 RUF ROD**



## INSTALLATION

1. Feed the rod through the lower rod guide or upper rod guide depending on the location and orientation of the duct with respect to the duct rodder.
2. For horizontal runs several feet above ground level, use the upper rod guide. For horizontal runs slightly above or below ground level, use the lower rod guide. For runs several feet below ground level where the rod must be fed vertically down a manhole, use the upper rod guide.
3. Feed the rod manually into the duct through to the far end of the duct. Use the brake handle as required to prevent rotation of the cage.
4. Attach the end of the rod to the utility being installed and pull back manually. The rod will recoil itself back into the cage.

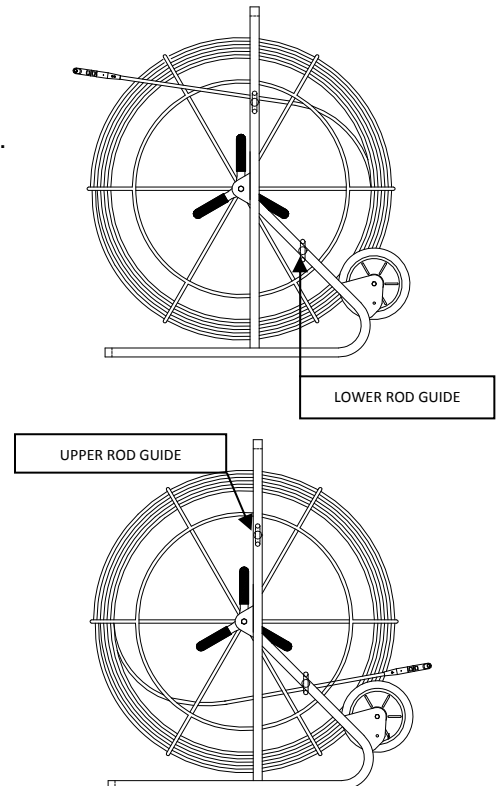

## SAFETY



1. Never bend the fiberglass rod around a corner with a radius less than the Minimum Bend Radius specified in the Operating Specifications.
2. A large amount of energy is stored in the coiled fiberglass rod. Always maintain control over the free end of the rod when the brake is not applied.
3. Be prepared for the unexpected. Use recognized safety practices and wear recognized safety equipment.