

OPERATING SPECIFICATIONS



**Design &
Manufacturing Ltd.**

SERIES 56200 DETECTABLE RODDER

1. The detectable rodder is intended for tracing a conduit using a utility locator transmitter and receiver.
Never use this conductive rod where live electrical circuits exist as electrical shock or death may occur.

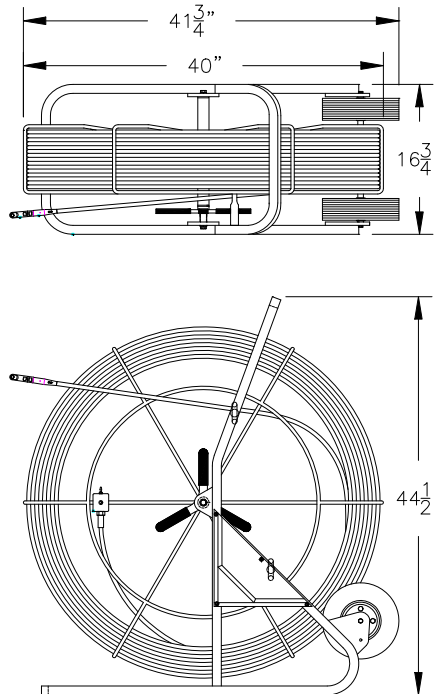

Part Number	Rod Length	Rod Diameter	Core Diameter	Min Bend Radius	Accessory Thread	Net Weight
56200-200	200 ft	0.440" 11 mm	0.300" 7.6 mm	16" 405 mm	3/8"-16	64 lb 29 kg
56200-400	400 ft	0.440" 11 mm	0.300" 7.6 mm	16" 405 mm	3/8"-16	74 lb 33 kg
56200-500	500 ft	0.440" 11 mm	0.300" 7.6 mm	16" 405 mm	3/8"-16	84 lb 38 kg
56200-600	600 ft	0.440" 11 mm	0.300" 7.6 mm	16" 405 mm	3/8"-16	94 lb 43 kg
56200-700	700 ft	0.440" 11 mm	0.300" 7.6 mm	16" 405 mm	3/8"-16	104 lb 47 kg
56200-800	800 ft	0.440" 11 mm	0.300" 7.6 mm	16" 405 mm	3/8"-16	114 lb 52 kg
56200-900	900 ft	0.440" 11 mm	0.300" 7.6 mm	16" 405 mm	3/8"-16	123 lb 56 kg
56200-1000	1000 ft	0.440" 11 mm	0.300" 7.6 mm	16" 405 mm	3/8"-16	144 lb 65 kg
56200-1500	1500 ft	0.440" 11 mm	0.300" 7.6 mm	16" 405 mm	3/8"-16	180 lb 82 kg

Dimensions and weights subject to change without notice.

For Standard Rodder units that do not include accessories, add "X" to the part number.

OPERATING INSTRUCTIONS



**Design &
Manufacturing Ltd.**

SERIES 56200 DETECTABLE RUF ROD



INSTALLATION

1. Feed the rod through the lower rod guide or upper rod guide depending on the location and orientation of the duct with respect to the rodder.
2. For horizontal runs several feet above ground level, use the upper rod guide. For horizontal runs slightly above or below ground level, use the lower rod guide. For runs several feet below ground level where the rod must be fed vertically down a manhole, use the upper rod guide.
3. Feed the rod manually into the duct through to the far end of the duct. Use the brake handle as required to prevent rotation of the cage.
4. Attach the direct lead from a locator transmitter to either the male or female banana clip on the junction box. Attach the other ground lead to a ground stake.
5. Set the receiver to the lowest frequency and trace out the path of the detectable rod. If the signal is difficult to trace, change to a higher transmitter frequency.

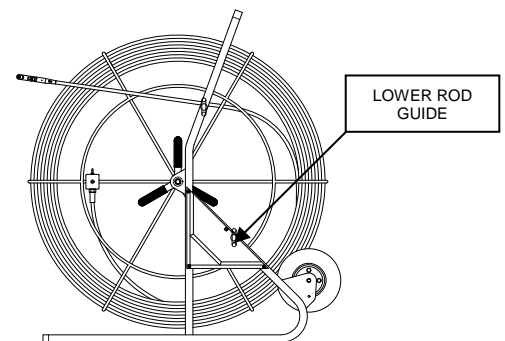
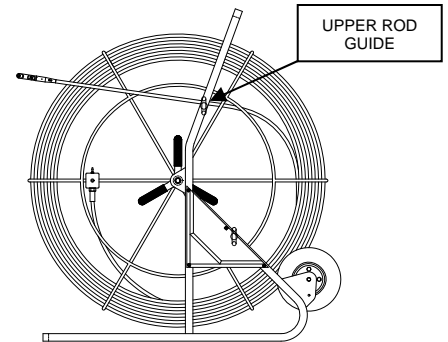

SAFETY



1. Never bend the fiberglass rod around a corner with a radius less than the Minimum Bend Radius specified in the Operating Specifications.
2. A large amount of energy is stored in the coiled fiberglass rod. Always maintain control over the free end of the rod when the brake is not applied.
3. Be prepared for the unexpected. Use recognized safety practices and wear recognized safety equipment.

EXTREME DANGER



NEVER USE THIS DETECTABLE RODDER IN A LIVE ELECTRICAL ENVIRONMENT, ELECTRICAL SHOCK OR DEATH MAY RESULT IF CONDUCTIVE ROD TOUCHES EXPOSED CIRCUIT.