

## DUB-Lite®

Specifically built for the HDD industry, DUB-Lite swivels feature a multiple sealing system which is progressive in design and application. Swivels 00503-X04 to 00503-X15 include a side-mounted grease nipple for easy access without having to remove the clevis pin. Greasing should be done after each use. The DUB-Lite® swivels utilize angular contact bearings for both pullback and pushback functions. All mechanical components are manufactured from high strength alloy steel and are designed to withstand a straight tensile load of at least 3 times the safe working load. The simplicity of this swivel allows field rebuilding and a rebuild kit comprised of bearings and seals is available.

The DCD Clevis Pin is specifically designed, machined and heat treated to provide the required strength and stability of the clevis. The clevis pins are hardened steel and are available as replacement kits. These clevis pins must not be replaced with simple hexagon bolts.

### Type 1 - API Box/Clevis

Type 1 swivels offer an API box connection at the leading end and a clevis connection at the trailing end. The rigid connection allows more straight forward pushback, but it also places a greater side load on the swivel.

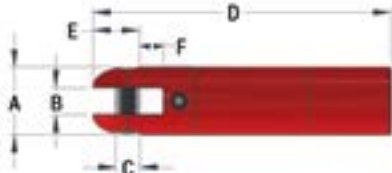

Part No.	3:1 Safe Working Load	Ultimate Load	Box Thread	A	B	C	D	E	F	Weight
00503-108-21F	15,000 lb	45,000 lb	2" IF API	2-1/2"	1"	7/8"	11-1/8"	1-3/4"	7/8"	10.1 lb

### Type 2 - Clevis/Clevis

The clevis by clevis style of swivel is the most common type and is the best for distributing side loads applied on the swivel due to its ability to pivot at either end. It does not allow the operator to push back without proper care and attention or the swivel may fold back on itself. Before rotation is recommenced, the line must be pulled straight or damage may occur to the swivel, as well as potential harm to nearby operators.

DCD recommends that some type of restrictor be used to prevent the swivel from pivoting at the front or reamer end. For swivels 00503-204 to 00503-215, the clevis is deeper at the leading end to allow the fool-proof design of a lug that would prevent more than minimal movement of the swivel away from the axis of rotation and also ensures the swivel is pulled in the right direction.

It is our recommendation to always select a swivel larger than the machine capacity. For more information, see bottom of page 6.



00503-202 to 00503-215

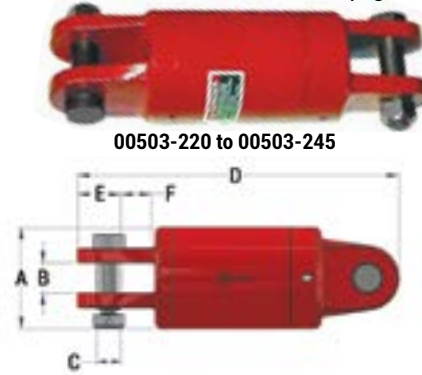

00503-220 to 00503-245

Part No.	3:1 Safe Working Load	Ultimate Load	A	B	C	D	E	F	G	Weight	Clevis Pin Kit	Rebuild Kit
00503-202	5,000 lb	15,000 lb	1-1/4"	1/2"	13/32"	4-31/32"	3/4"	1/2"	9/16"	1.08 lb	00020-HEX	-
00503-204	8,500 lb	25,500 lb	2"	3/4"	11/16"	8-3/4"	1-3/8"	5/8"	3/4"	5.00 lb	00035-HEX	00503-K04
00503-205	10,000 lb	30,000 lb	2-1/4"	7/8"	3/4"	9-5/8"	1-1/2"	3/4"	7/8"	7.00 lb	00037-HEX	00503-K05
00503-208	15,000 lb	45,000 lb	2-1/2"	1"	7/8"	11-1/4"	1-3/4"	7/8"	1"	10.1 lb	00040-HEX	00503-K08
00503-210	20,000 lb	60,000 lb	2-1/2"	1"	7/8"	11-7/8"	1-3/4"	7/8"	1"	10.7 lb	00040-HEX	00503-K10
00503-215	30,000 lb	90,000 lb	3"	1-5/16"	1-1/8"	14"	2-1/4"	1-1/8"	1-1/4"	17.3 lb	00045-HEX	00503-K15
00503-220	40,000 lb	120,000 lb	4-3/4"	1-3/4"	1-1/8"	16-1/2"	2-1/16"	1-7/16"	-	49.0 lb	00508-015	-
00503-230	60,000 lb	180,000 lb	5-3/4"	1-3/4"	1-3/8"	18-1/4"	2-1/2"	1-7/16"	-	76.0 lb	00508-020	-
00503-245	90,000 lb	270,000 lb	6"	1-3/4"	1-3/8"	19-3/8"	2-1/2"	1-7/16"	-	88.0 lb	00508-020	-

## Type 3 - Flange/Lug

This style is specifically designed for directional drilling applications. It is intended to be mounted internally into a back reamer using a bolt flange. This type of swivel permits rotation of the drill pipe while protecting the utility from twisting.

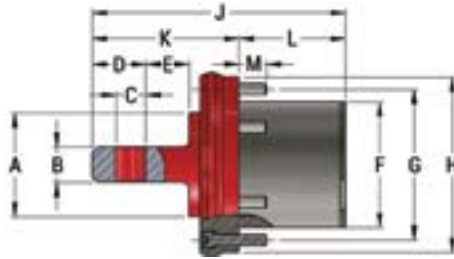

Part No.	3:1 Safe Working Load	Ultimate Load	A	B	C	D	E	F	G	H	J	K	L	M	Flange Bolts	Weight
00503-330	60,000 lb	180,000 lb	4-3/4"	1-5/8"	1-3/8"	2-15/32"	2"	5-3/4"	6-7/8"	8"	11-19/32"	6-3/4"	4-7/8"	1-1/4"	6 x 1/2" UNC	66.0 lb

## Type 6 - Flange/Clevis

This style is intended to be mounted internally into a back reamer using a bolt flange. Hard surfacing is applied around the perimeter for extra durability. This type of swivel permits pushback without any fold-back possibility.

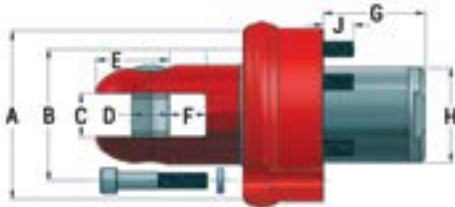

Part No.	3:1 Safe Working Load	Ultimate Load	A	B	C	D	E	F	G	H	J	Flange Bolts	Weight
00503-610	20,000 lb	60,000 lb	5-1/4"	4"	1"	7/8"	1-3/4"	7/8"	2-9/16"	2-7/8"	1"	6 x 1/2" UNC	18.0 lb
00503-615	30,000 lb	90,000 lb	5-1/4"	4"	1-5/16"	1-1/8"	2-1/4"	1-1/8"	3-1/8"	2-7/8"	1"	6 x 1/2" UNC	20.0 lb
00503-620	40,000 lb	120,000 lb	8"	6-7/8"	1-3/4"	1-1/8"	2-1/16"	2"	4"	4-3/4"	1-1/4"	6 x 1/2" UNC	51.0 lb
00503-630	60,000 lb	180,000 lb	8"	6-7/8"	1-3/4"	1-1/8"	2-1/16"	2"	4-7/8"	5-3/4"	1-1/4"	6 x 1/2" UNC	66.0 lb

## Type 7 - Clevis/Pin

Type 7 swivels offer a pin connection to the reamer or hole-opener ahead of the swivel. There are several different types and sizes of threaded connections (see chart for details). The rigid connection allows more straightforward pushback, but also places a greater side load on the swivel.

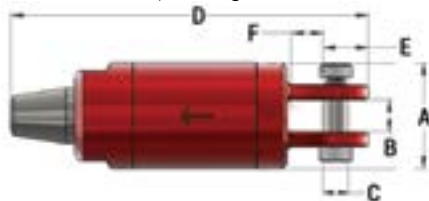

Part No.	3:1 Safe Working Load	Ultimate Load	Male Pin Thread	A	B	C	D	E	F	Weight
00503-705-21M	10,000 lb	30,000 lb	2" IF API	2-1/2"	7/8"	3/4"	11-5/16"	1-1/2"	3/4"	9.9 lb
00503-710-21M	20,000 lb	60,000 lb	2" IF API	2-1/2"	1"	7/8"	12-11/16"	1-3/4"	7/8"	12.6 lb
00503-710-23M	20,000 lb	60,000 lb	2-3/8" Reg API	3-1/4"	1"	7/8"	13-7/8"	1-3/4"	7/8"	13.0 lb
00503-715-23M	30,000 lb	90,000 lb	2-3/8" Reg API	3-1/4"	1-5/16"	1-1/8"	15"	2-1/4"	1-1/8"	20.8 lb
00503-720-23M	40,000 lb	120,000 lb	2-3/8" Reg API	4-3/4"	1-3/4"	1-1/8"	17-1/2"	2-1/16"	1-7/16"	55.0 lb
00503-730-27M	60,000 lb	180,000 lb	2-7/8" IF API	5-3/4"	1-3/4"	1-3/8"	19-9/16"	2-1/2"	1-7/16"	88.0 lb
00503-745-27M	90,000 lb	270,000 lb	2-7/8" IF API	6"	1-3/4"	1-3/8"	20-3/4"	2-1/2"	1-7/16"	100.0 lb
00503-715V+	30,000 lb	90,000 lb	2.06-8 Vermeer® Starter Rod	3"	1-5/16"	1-1/8"	15-3/8"	2-1/4"	1-1/8"	19.4 lb

\* Vermeer® is a registered trademark and the property of Vermeer Manufacturing Company.

## DUB-In™

This series of built-in swivels is designed to act as a replacement for the original swivel fitted to reamers manufactured by the leading OEMs.

Several OEMs offer reamers with a pocket to mount a bolt flange style swivel; others offer reamers with a female threaded pocket to mount a screw in swivel which is then secured with a hexagon collar. However, swivels are not their leading product, directional drilling machines are. DCD Design & Manufacturing is in the business of designing and building swivels and the products shown on this page all offer substantial improvements over the OEM product.

Features include:

- Multiple-stage sealing system.
- Side mounted grease nipple for thorough greasing.
- Hard weld surround on flange to prevent wear at the head of the securing bolts.
- Angular contact bearings provide durability and excellent axial capacity. They have been maximized within the design of the reamer.
- Clevis connection with high strength, hardened and replaceable clevis pins. No longer a need for shackles to complete the connection.
- Completely self contained unit with jacking screws for easy removal.
- Both types feature a water port with plug.
- No modifications necessary to the reamer – simply use these as replacement parts.

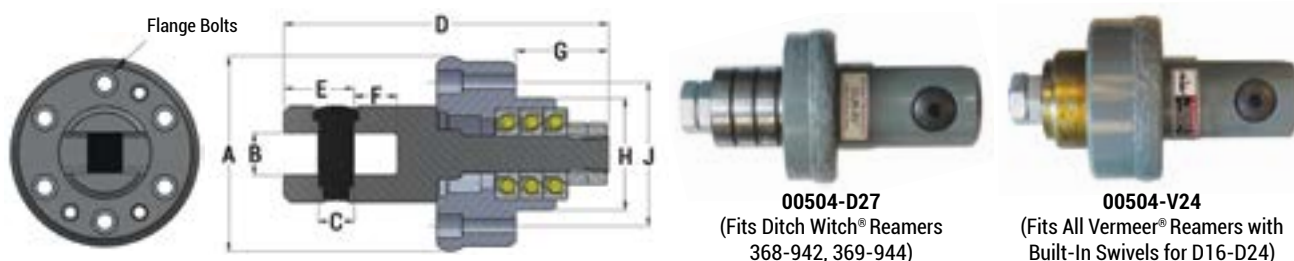

Part No.	3:1 Safe Working Load	Ultimate Load	A	B	C	D	E	F	G	H	J	Flange Bolts	Weight
00504-D27*	27,000 lb	81,000 lb	5-7/8"	1-1/4"	1-1/8"	10-1/8"	2-1/8"	1-3/8"	3-7/8"	2.835"	3-17/32"	6 x 3/8" UNC	17 lb
00504-V24**	24,000 lb	72,000 lb	6-1/4"	1-5/16"	1-1/8"	10-1/8"	2-1/8"	1-3/8"	2-15/16"	3.500"	4-1/2"	6 x 1/2" UNC	24 lb

\* Ditch Witch® is a registered trademark and the property of The Charles Machine Works Co. Inc.

\*\* Vermeer® is a registered trademark and the property of Vermeer Manufacturing Company.

## DUB-Swivel®

These pullback swivels are designed specifically for horizontal directional drilling applications and after more than 20 years, they have proven capable of the challenge. When DCD Design patented the "Harsh Environment Swivel" in 1996, it was ahead of its time. The most important feature of the DUB-Swivel® design was the sealing system: multiple stages became progressively finer to exclude sand and other coarse particles that can easily destroy a seal.

DCD DUB-Swivels® start with a gap seal to keep out larger particles, then a mechanical seal with lapped steel rings rotating against each other. This seal was designed for abrasive environments: military tank drivetrains, bulldozers, and cement mixers. For the final stage of protection, a lip seal is used directly in front of the bearings.

In addition to the sealing system, these swivels offer an easily accessible lubrication system complete with relief valve. A high-quality grease formulation fills the bearing cavity, providing an immersed physical barrier to the rotating bearing elements. Regular maintenance – topping up the grease in small quantities – will ensure a full charge of clean lubricant is always protecting the bearings. Units are also rebuildable.

The bearing arrangement in the DUB-Swivels® is another key to their durability. DUB-Swivels® use back-to-back tapered roller bearings in the smaller sizes up to and including 20 ton capacity. The design life-span of DUB-Swivel® bearings are in excess of 700 hours. This life-span is based on proper usage of the swivel - severe side or shock loads as well as maintenance and care will affect these expectations. Close attention must be paid to the product information sheets that accompany each swivel shipped.

It is our recommendation to always select a swivel larger than the machine capacity. It is usually more cost effective when this is done and, if the product is used carefully, life-span in excess of 3,000 hours have been recorded.

All DUB-Swivel® mechanical components are designed to withstand a straight tensile load of 5 times the safe working limit. DUB-Swivels® with a 20 ton capacity and larger are built with individually assigned serial numbers and complete material traceability for every component.

## Type 1 - API Box/Clevis

Type 1 swivels offer an API box connection at the leading end and a clevis connection at the trailing end. The rigid connection allows more straight forward pushback, but it also places a greater side load on the swivel.



Part No.	5:1 Safe Working Load	Ultimate Load	Box Thread	A	B	C	D	E	F	Weight	Pin Kit
00508-115C	30,000 lb	150,000 lb	2-3/8" IF API	4-3/4"	1-3/4"	1-1/8"	17-7/8"	2-7/16"	1-9/16"	61 lb	00508-P015
00508-120C	40,000 lb	200,000 lb	2-3/8" IF API	5-3/4"	1-3/4"	1-3/8"	19-3/8"	2-7/16"	1-9/16"	79 lb	00508-P020
00508-120D	40,000 lb	200,000 lb	2-7/8" IF API	5-3/4"	1-3/4"	1-3/8"	19-1/2"	2-7/16"	1-9/16"	90 lb	00508-P020
00508-130D	60,000 lb	300,000 lb	2-7/8" IF API	6"	1-3/4"	1-3/8"	19-1/2"	2-7/16"	1-9/16"	94 lb	00508-P020
00508-130E	60,000 lb	300,000 lb	3-1/2" IF API	6"	1-3/4"	1-3/8"	20"	2-7/16"	1-9/16"	90 lb	00508-P020
00508-140E	80,000 lb	400,000 lb	3-1/2" IF API	6-1/2"	2-1/8"	1-3/4"	24-7/8"	3-1/4"	2"	144 lb	00508-P040
00508-140F	80,000 lb	400,000 lb	4-1/2" IF API	6-1/2"	2-1/8"	1-3/4"	26"	3-1/4"	2"	168 lb	00508-P040
00508-160F	120,000 lb	600,000 lb	4-1/2" IF API	7-1/2"	2-3/4"	2-1/8"	30-7/8"	3-9/16"	2-3/16"	257 lb	00508-P060
00508-180F	160,000 lb	800,000 lb	4-1/2" IF API	9"	3-1/4"	2-1/2"	32-5/8"	4-13/16"	2-13/16"	368 lb	00508-P080

US Patent # 5,529,421

Canadian Patent # 2,109,041

Maxi DUB-Swivel is a Registered Trade Mark

## Type 2 - Clevis/Clevis

Type 2 swivels offer a clevis connection at both ends with hardened, lockable clevis pins. This style of swivel is the most common type and is the best for distributing side loads applied on the swivel due to its ability to pivot at either end. It does not allow the operator to push back without proper care and attention or the swivel may fold back on itself. When rotation is recommended, the line must be pulled straight or damage may occur to the clevis ends.

Because the DCD Clevis Pin is a precision machined product specifically designed to fit the clevis, field substitution with any other pins is not recommended. Doing so may cause serious danger to operators and equipment and will immediately void any warranty or liability for the product.



Part No.	5:1 Safe Working Load	Ultimate Load	A	B	C	D	E	F	G	Weight	Clevis Pin Kit
00508-202	5,000 lb	25,000 lb	2"	2"	1"	11/16"	1-3/16"	13/16"	7-1/2"	3.8 lb	00508-002
00508-205	10,000 lb	50,000 lb	3-1/8"	2-1/4"	1-1/4"	3/4"	1-1/4"	1-1/4"	11-1/16"	15 lb	00508-005
00508-210	20,000 lb	100,000 lb	3-3/4"	2-3/4"	1-1/2"	1"	1-5/8"	1-1/16"	13-9/16"	27 lb	00508-010
00508-215	30,000 lb	150,000 lb	4-3/4"	3-1/4"	1-3/4"	1-1/8"	2-1/16"	1-7/16"	17-3/8"	57 lb	00508-015
00508-220	40,000 lb	200,000 lb	5-3/4"	3-1/2"	1-3/4"	1-3/8"	2-1/2"	1-9/16"	18-1/2"	83 lb	00508-020
00508-230	60,000 lb	300,000 lb	6"	3-1/2"	1-3/4"	1-3/8"	2-1/2"	1-9/16"	18-1/2"	85 lb	00508-020
00508-240	80,000 lb	400,000 lb	6-1/2"	4-5/8"	2-1/8"	1-3/4"	3-1/4"	2-1/4"	24-11/16"	150 lb	00508-040
00508-250	100,000 lb	500,000 lb	7-1/2"	5-1/2"	2-3/4"	2-1/8"	3-5/8"	2-5/8"	26-3/8"	230 lb	00508-060
00508-260	120,000 lb	600,000 lb	7-1/2"	5-1/2"	2-3/4"	2-1/8"	3-9/16"	2-1/4"	28-1/2"	250 lb	00508-060
00508-280	160,000 lb	800,000 lb	9"	6"	3-1/4"	2-1/2"	4-13/16"	2-7/8"	33-7/8"	380 lb	00508-080

## Type 6 - Clevis/Flange (Stub-E-DUB™)

Type 6 swivels are specially designed to fit inside custom built reamers. There are several manufacturers making these specific reamers. They have a mounting flange allowing assembly into the reamer and thereby reducing the gap back to the utility being installed. These swivels are totally self contained and greasable.

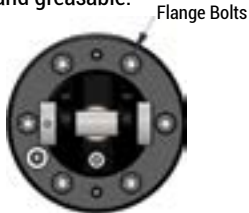

Part No.	5:1 Safe Working Load	Ultimate Load	A	B	C	D	E	F	G	H	J	Flange Bolts	Weight
00508-605	10,000 lb	50,000 lb	5"	4"	1-1/4"	3/4"	1-1/4"	1"	3-1/2"	2-7/8"	7/8"	6 x 3/8 UNC	14 lb
00508-610	20,000 lb	100,000 lb	6-1/8"	4-7/8"	1-1/2"	1"	1-9/16"	1-1/16"	4-3/16"	3-5/8"	1-1/8"	6 x 1/2 UNC	27 lb
00508-615	30,000 lb	150,000 lb	7-1/4"	5-7/8"	1-3/4"	1-1/8"	2"	1-9/16"	5-1/4"	4-3/8"	1-3/16"	6 x 5/8 UNC	48 lb
00508-620	40,000 lb	200,000 lb	9-1/2"	7-3/4"	1-3/4"	1-3/8"	2-7/16"	1-9/16"	6-1/16"	6"	1-1/16"	8 x 3/4 UNC	94 lb
00508-630	60,000 lb	300,000 lb	9-1/2"	7-3/4"	1-3/4"	1-3/8"	2-7/16"	1-9/16"	6-1/16"	6"	1-1/16"	8 x 3/4 UNC	98 lb
00508-640	80,000 lb	400,000 lb	9-1/2"	7-3/4"	2-1/8"	1-3/8"	3-1/4"	2"	8"	6"	1-1/16"	8 x 3/4 UNC	123 lb
00508-660*	120,000 lb	600,000 lb	10-3/4"	9"	2-3/4"	2-1/8"	3-9/16"	2-3/16"	9-5/8"	7-1/2"	1-3/8"	6 x 3/4 UNC	198 lb

\* Custom order only.

## Type 7 - Clevis/Pin

Type 7 swivels offer a pin connection to the reamer or hole-opener ahead of the swivel. There are several different types and sizes of threaded connections, see the chart for details. The rigid connection allows more straightforward pushback, but it also places a greater side load on the swivel.

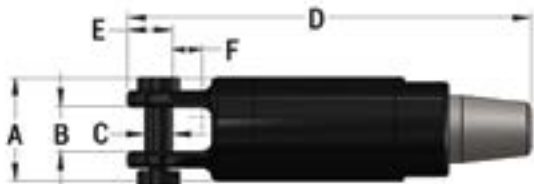

Part No.	5:1 Safe Working Load	Ultimate Load	Male Pin Thread	A	B	C	D	E	F	Weight	Pin Kit
00508-710-23M	20,000 lb	100,000 lb	2-3/8" Reg API	3-3/4"	1-1/2"	1"	14-5/8"	1-9/16"	1-1/16"	29 lb	00508-P010
00508-715-23M	30,000 lb	150,000 lb	2-3/8" Reg API	4-3/4"	1-3/4"	1-1/8"	17-1/16"	2"	1-9/16"	55 lb	00508-P015
00508-715-27M	30,000 lb	150,000 lb	2-7/8" IF API	4-3/4"	1-3/4"	1-1/8"	17-3/4"	2"	1-9/16"	76 lb	00508-P015
00508-720-27M	40,000 lb	200,000 lb	2-7/8" IF API	5-3/4"	1-3/4"	1-3/8"	19-1/8"	2-7/16"	1-9/16"	84 lb	00508-P020
00508-730-27M	60,000 lb	300,000 lb	2-7/8" IF API	6"	1-3/4"	1-3/8"	19-1/8"	2-7/16"	1-9/16"	87 lb	00508-P020
00508-740-27M	80,000 lb	400,000 lb	2-7/8" IF API	6-1/2"	2-1/8"	1-3/4"	23-11/16"	3-1/4"	2"	142 lb	00508-P040
00508-710V	20,000 lb	100,000 lb	2.06-8" Starter Rod	3-3/4"	1-1/2"	1"	16"	1-9/16"	1-1/16"	29 lb	00508-P010
00508-715V	30,000 lb	150,000 lb	2.06-8" Starter Rod	4-3/4"	1-3/4"	1-1/8"	18-1/2"	2"	1-9/16"	55 lb	00508-P015

US Patent # 5,529,421

Canadian Patent # 2,109,041

Maxi DUB-Swivel is a Registered Trade Mark

## The Lifespan of a Swivel

At the safe working load and under standard conditions, a swivel's bearing will last for one million revolutions. At one-half the safe working load, it will last significantly longer: eight million revolutions. Both these calculations presume the swivel and grease are not compromised.

In short, the harder you work a swivel, the shorter the lifespan – and the relationship is not linear! The load on the swivel is one factor. The care and maintenance you provide for the equipment is another major factor.

To last for eight million revolutions, the swivel and its bearing will need lubrication at regular intervals. Since the frequency of maintenance will directly affect the level of reliability, we recommend lubrication after every pullback to keep the grease in the best possible condition.

## Pin Kits for DUB-Lite®, DUB-In™, & DUB-Swivels®

There are three different pin kits available for the various types and sizes of our DUB line of swivels.

Pin Kit No.	Allen Key Size	Type 2	Type 6	Type 7	Other
00035-HEX	00101-375 (3/8")	00503-204	-	-	-
00037-HEX	00101-375 (3/8")	00503-205	-	00503-705-21M	-
00040-HEX	00101-375 (3/8")	00503-208 00503-210	00503-610	00503-710-21M 00503-710-23M	-
00045-HEX	00101-375 (3/8")	00503-215	00503-615	00503-715-23M 00503-715V	00504-D27 00504-V24



Pin Kit No.	Allen Key Size	Type 1	Type 6	Type 7
00508-P005	00101-156 (5/32")	-	00508-605	-
00508-P010	00101-187 (3/16")	-	00508-610	-
00508-P015	00101-187 (3/16")	00508-115C	00508-615	-
00508-P020	00101-187 (3/16")	00508-120C 00508-120D 00508-130D 00508-130E	00508-620 00508-630	00503-720-23M 00508-720-27M 00503-730-23M 00508-730-27M 00503-745-23M 00503-745-27M
00508-P040	00101-250 (1/4")	00508-140E 00508-140F	00508-640	00508-720-27M
00508-P060	00101-250 (1/4")	00508-160F	00508-660	-
00508-P080	00101-312 (5/16")	00508-180F	-	-
00508-P110	00101-312 (5/16")	00508-1110	-	-
00508-P165	00101-312 (5/16")	00508-1165	-	-
00508-P220	00101-375 (3/8")	00508-1220	-	-
00508-P275	00101-375 (3/8")	00508-1275	-	-
00508-P350	00101-500 (1/2")	00508-1350 00508-1351	-	-
00508-P500	00101-625 (5/8")	00508-1500 00508-1501	-	00508-7500
00508-P700	00101-625 (5/8")	00508-1700	-	00508-7700



Pin Kit No.	Allen Key Size	Type 2
00508-002	00101-375 (3/8")	00508-202
00508-005	00101-156 (5/32")	00508-205
00508-010	00101-187 (3/16")	00508-210
00508-015	00101-187 (3/16")	00503-220 00508-215
00508-020	00101-187 (3/16")	00503-230 00503-245 00508-220 00508-230
00508-040	00101-250 (1/4")	00508-240
00508-060	00101-250 (1/4")	00508-260
00508-080	00101-312 (5/16")	00508-280



## Maxi DUB-Swivel®

DCD's Maxi DUB-Swivel® is essentially a scaled-up version of our DUB-Swivel, utilizing the same sealing system in which multiple stages become progressively finer to exclude coarse particles that could otherwise easily destroy the seal. This design starts with a gap seal to keep out larger particles, followed by a mechanical seal with lapped steel rings that rotate against each other. This type of seal is ideal for abrasive environments, such as cement mixers, military tank drivetrains, and bulldozers. A lip seal used directly in front of the bearings then provides the final stage of protection.

In addition to the sealing system, Maxi DUB-Swivels offer an easily accessible lubrication system complete with relief valve. The bearing cavity is filled with a high-quality grease formulation, providing an immersed physical barrier to the rotating bearing elements. Regular maintenance, such as topping up the grease in small quantities, will ensure a full charge of clean lubricant is always protecting the bearings.

The Maxi DUB-Swivels® use a combination of bearings to provide tensile and side load support. This arrangement was pioneered by DCD Design, proven in service, and more recently, duplicated by our competitors.

The Maxi DUB-Swivel® bearings are designed to provide a life span in excess of 700 hours. This life span is based on proper usage of the swivel – severe side or shock loads as well as maintenance and care will affect these expectations.

All mechanical components are designed to withstand a tensile load of 3-1/2 times the safe working limit typically.

All Maxi DUB-Swivels® are built with individually assigned serial numbers and complete material traceability for every component.

For information on replacement Pin Kits, please see page 7. Seal kits are also available upon request.



## Type 1 - API Box / Clevis for Maxi Rigs

The increased range of Maxi-Rig swivels is designed to better fit the capacities of the most common rig manufactures. Type 1 swivels offer an API box connection at the leading end and a clevis connection at the trailing end. The rigid connection allows more straight forward pushback, but it also places a greater side load on the swivel.

This special series is designed with service in mind. The seal cover is removable and all seals can be replaced in the field without need for major disassembly. Factory service can be scheduled to keep the Maxi-DUB Swivel® running smoothly; this preventative maintenance will keep the swivel operating longer.

Note: Additional thread options are available upon request.

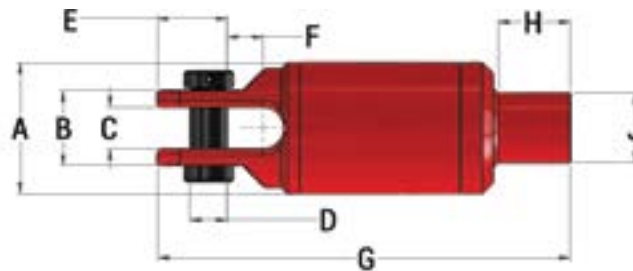

Part No.	Safe Working Limit	Ultimate Load	Box Thread	A	B	C	D	E	F	G	H	J	Weight
00508-1110*	110 ton 100 tonne	400 ton 360 tonne	4-1/2" IF API	10-3/4" 273 mm	6" 152 mm	3-1/4" 83 mm	2-1/2" 64 mm	4-3/4" 121 mm	2-7/8" 72 mm	35" 889 mm	7-1/2" 190 mm	6-5/8" 169 mm	420 lb 190 kg
00508-1165*	165 ton 150 tonne	600 ton 540 tonne	4-1/2" IF API	10-3/4" 273 mm	6-1/2" 165 mm	3-1/2" 89 mm	3" 76 mm	5-1/2" 140 mm	3" 76 mm	38" 965 mm	7-1/2" 190 mm	6-5/8" 169 mm	570 lb 258 kg
00508-1220*	220 ton 200 tonne	750 ton 680 tonne	6-5/8" Reg API	12-1/2" 318 mm	7" 178 mm	4" 102 mm	3-1/2" 89 mm	6-1/2" 165 mm	4" 102 mm	41-7/8" 1,064 mm	8-1/4" 209 mm	7-3/4" 196 mm	846 lb 383 kg
00508-1275**	275 ton 250 tonne	1,000 ton 907 tonne	6-5/8" FH API	14-1/2" 368 mm	8-9/16" 217 mm	4-1/2" 114 mm	4" 102 mm	7" 178 mm	3-1/2" 89 mm	42-7/16" 1,078 mm	8-7/16" 214 mm	8-1/2" 216 mm	1,500 lb 681 kg
00508-1351	350 ton 320 tonne	1,250 ton 1,130 tonne	6-5/8" FH API	16" 406 mm	9" 229 mm	5" 127 mm	4-1/2" 114 mm	8-1/2" 216 mm	4-1/2" 114 mm	50-11/16" 1,287 mm	8-7/8" 225 mm	8-7/8" 225 mm	1,690 lb 770 kg
00508-1501	500 ton 450 tonne	1,750 ton 1,580 tonne	6-5/8" FH API	23" 584 mm	10-1/2" 267 mm	5-1/2" 140 mm	5-1/2" 140 mm	9-3/4" 248 mm	5-1/4" 133 mm	55-9/16" 1,411 mm	8-7/8" 225 mm	8-7/8" 225 mm	2,540 lb 1,150 kg
00508-1700**	700 ton 640 tonne	2,500 ton 2,270 tonne	7-5/8" Reg API	23" 584 mm	12-1/2" 318 mm	6-1/2" 165 mm	6-1/2" 165 mm	11-1/2" 292 mm	5-1/2" 140 mm	65-7/16" 1,663 mm	9-1/2" 241 mm	9-1/4" 234 mm	4,120 lb 1,880 kg

\* Also available in a high pressure version; made to order.

\*\* Sizes made to order.

US Patent # 5,529,421  
Canadian Patent # 2,109,041  
Maxi DUB-Swivel is a Registered Trade Mark

## Type 7 - API Pin / Clevis for Maxi Rigs

Type 7 Maxi-DUB Swivels® with an API pin connection (to the reamer or hole-opener ahead of the swivel) are a special-order option. The specifications are identical to the standard Type 1 Maxi-DUB Swivels®. Custom threads are available; contact Customer Service for more details.

Note: Type 7 Maxi DUB-Swivels are made to order.

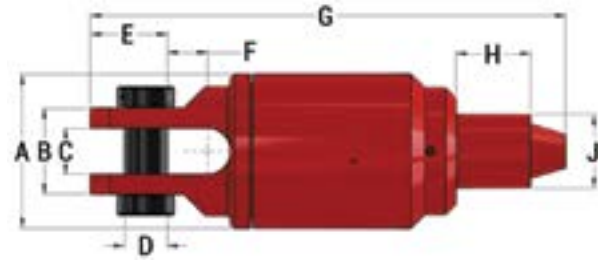

Part No.	Safe Working Limit	Ultimate Load	Pin Thread	A	B	C	D	E	F	G	H	J	Weight
00508-7500	500 ton	1,750 ton	6-5/8"	19-1/2"	10-1/2"	5-1/2"	5-1/2"	9-3/4"	5-1/4"	64-3/4"	12-1/8"	9-1/4"	2,700 lb
	450 tonne	1,580 tonne	FH API	495 mm	267 mm	140 mm	140 mm	248 mm	133 mm	1,645 mm	308 mm	235 mm	1,230 kg
00508-7700	700 ton	2,500 ton	6-5/8"	23"	12-1/2"	6-1/2"	6-1/2"	11-1/2"	5-1/2"	72-11/16"	12-1/8"	9-1/4"	4,120 lb
	640 tonne	2,270 tonne	FH API	584 mm	318 mm	165 mm	165 mm	292 mm	140 mm	1,847 mm	308 mm	235 mm	1,880 kg

## Type 8 - API Box / Lug for Maxi Rigs

Special applications call for special solutions: Type 8 Maxi-DUB Swivels® have been built to customer specifications to fit shackle connections. Otherwise specifications are identical to the standard Type 1 Maxi-DUB Swivels®; contact Customer Service for more details.

Note: Type 8 Maxi DUB-Swivels are made to order.

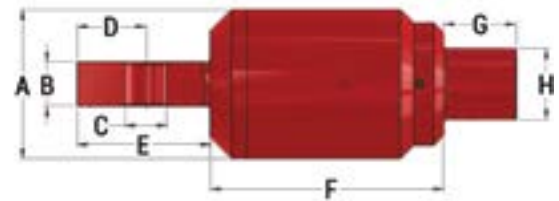

Part No.	Safe Working Limit	Ultimate Load	Box Thread	A	B	C	D	E	F	G	H	Weight
00508-8500	500 lb	1,750 ton	7-5/8"	19-1/2"	5-3/4"	5-1/2"	9"	17-7/16"	57-9/16"	9-1/4"	9-1/4"	2,700 lb
	450 tonne	1,580 tonne	REG API	495 mm	146 mm	140 mm	229 mm	444 mm	1,461 mm	234 mm	234 mm	1,230 kg
00508-8501	500 ton	1,750 ton	7-5/8"	19-1/2"	6-7/8"	5-7/16"	9"	16-3/16"	56-5/16"	9-1/4"	9-1/4"	2,700 lb
	450 tonne	1,580 tonne	REG API	495 mm	175 mm	138 mm	229 mm	412 mm	1,430 mm	234 mm	234 mm	1,230 kg

## Specialty Swivels

The engineers at DCD have designed and developed several new DUB-Swivels, ranging from an auger boring version to what we've termed Clutch Swivels, which have locking sleeves that can allow free rotation and the transmission of torque up to 27,500 ft-lb. Some of the Clutch Swivels also have a through-bore feature that allows drilling fluid to pass through the swivel at pressures up to 1,500 psi. These brand new products add a versatile touch to our DUB-Swivel line.

## Type 9 DUB-Swivel® (Hex Auger Boring)

The 00508-940 Type 9 DUB-Swivel® is an auger boring swivel, used in the guided auger boring process and installed in compression between the pilot rods and auger casing to prevent the rods from rotating as they enter the pit. The unit has a maximum compression safe working load of 80,000 lb (5:1), maximum tension of 20,000 lb, a maximum rotation speed of 90 RPM, and external fluid pressure limit of 1,500 psi. Each end of the swivel is designed with a 3" female hex.



Part No.	Safe Working Limit (Compression)	Ultimate Load (Compression)	Maximum Rotational Speed	Box Thread	A	B	C	D	E	F	G	Weight
00508-940	80,000 lb	400,000 lb	90 RPM	3-1/2"	6-15/32"	5-3/8"	4-1/2"	5-15/32"	5-1/8"	18-11/16"	1-1/8"	96 lb
	356 kN	1,779 kN		Custom	164 mm	137 mm	114 mm	139 mm	130 mm	475 mm	29 mm	44 kg



## Clutch DUB-Swivel®

This DUB-Swivel has the same 40,000 lb safe working load as its standard 00508-120D version, but unlike that version, the 00508-120L has a pin connection at the leading end, a box connection at the trailing end, a locking sleeve, and a 1-1/8" bore through the swivel. The locking sleeve can be secured in or out of position, allowing free rotation or the transfer of torque up to 2,000 ft-lb and a maximum inner bore fluid pressure of 300 psi to allow the passage of drilling fluid.



Part No.	Safe Working Limit	Ultimate Load	Maximum Locking Torque	Drilling Fluid Pressure Rating	Box Thread	Pin Thread	A	B	C	D	E	Net Weight
00508-120L	40,000 lb 178 kN	200,000 lb 890 kN	2,000 ft-lb 2,712 Nm	300 psi 2.068 MPa	3-1/2" Custom	3-1/2" Custom	5-3/4" 146 mm	6-1/2" 165 mm	18-15/16" 481 mm	3-7/8" 98 mm	3-3/4" 95 mm	96 lb 44 kg
00508-180L	160,000 lb 712 kN	800,000 lb 3,560 kN	32,000 ft-lb 43,386 Nm	580 psi 3.999 MPa	4-1/2" IF API	4-1/2" IF API	8-31/32" 228 mm	9-3/4" 248 mm	34-1/8" 867 mm	7-1/2" 191 mm	6-5/8" 168 mm	368 lb 167 kg

## Clutch Maxi DUB-Swivel®

This is a locking version of our regular 110T Maxi DUB-Swivel®. Like other locking swivels, the sleeve can be secured in or out of its locked position, allowing free rotation or the transmission of torque up to 27,500 ft-lb. The unit comes standard with a 4-1/2" IF Box connection on each end.

The locking Flow-Thru Swivel is a 220T Maxi DUB-Swivel® specifically intended for coupling with the drill string. It is designed with a 6-5/8" API connection on each end, a locking sleeve, and a clear 3" bore through the center of the swivel. The swivel locking sleeve can be unbolted to allow rotation or bolted to transmit up to 180,000 ft-lb of torque. The locking sleeve can be engaged or disengaged without removing the swivel from the drill string. The thru-bore will allow the passage of drilling fluid through the swivel at pressures up to 1500 psi.

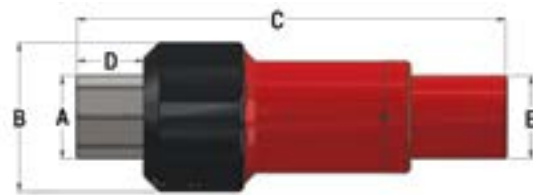

Part No.	Safe Working Limit	Safe Working Limit (Compression)	Ultimate Load (Tension)	Maximum Locking Torque	Box Thread (Free End)	Box Thread (Fixed End)	Internal Pressure Rating	External Pressure Rating	A	B	C	D	E	Net Weight
00508-1110L	110 ton 100 tonne	58 ton 52.6 tonne	400 ton 360 tonne	27,500 ft-lb 37,285 Nm	4-1/2" IF API	4-1/2" IF API	580 psi 4.00 MPa	25 psi 0.172 MPa	6-5/8" 168 mm	12" 305 mm	34-5/8" 880 mm	5-7/16" 138.1 mm	6-21/32" 169 mm	420 lb 190 kg
00508-1165L	165 ton 150 tonne	66 ton 59.8 tonne	600 ton 540 tonne	27,500 ft-lb 37,285 Nm	4-1/2" IF API	4-1/2" IF API	580 psi 4.00 MPa	25 psi 0.172 MPa	6-21/32" 169 mm	12" 305 mm	35-1/2" 902 mm	5-15/32" 138.9 mm	6-21/32" 169 mm	529 lb 240 kg
00508-1220L	220 ton 200 tonne	66 ton 59.8 tonne	750 ton 680 tonne	180,000 ft-lb 244,047 Nm	6-5/8" Reg API	5-1/2" FH API	580 psi 4.00 MPa	25 psi 0.172 MPa	7-3/4" 197 mm	14" 356 mm	37" 940 mm	5-5/8" 142.9 mm	7" 178 mm	766 lb 348 kg

## Swivel Grease

Renolit S<sub>2</sub>TX is a high performance lithium complex grease formulated with highly refined mineral oil and synthetic base stocks. This, along with its state-of-the-art additive system, gives Renolit S<sub>2</sub>TX the utmost in performance and protection of your equipment. Renolit S<sub>2</sub>TX is very resistant to water washout, even in salt water. Its high Timken OK load of 75 lb, along with high dropping point of 525°F, makes it one grease for all applications.



Grease Fitting Needle (90030-023)

Check for compatibility if using alternate grease types.

Part No.	Description	Size	Weight
90030-001	Fuchs Renolit S <sub>2</sub> TX Grease Tube	1 x 411 g	1 lb
90030-003	Fuchs Renolit S <sub>2</sub> TX Grease Drum	1 x 54.4 kg	124 lb
90030-010	Fuchs Renolit S <sub>2</sub> TX Grease Case	10 x 411 g	10 lb
90030-023	Grease Fitting Needle for 00505 Line Swivels	3" Length	0.05 lb

	Compatible	Incompatible	Borderline
DCD Lithium Complex	Aluminum Complex Calcium Stearate Calcium 12 Hydroxy Calcium Complex	Calcium Suffronate Lithium Stearate Lithium 12 Hydroxy Silica Gel	Barium Complex Bentone (Clay) Polyurea Sodium Soap