

OPERATING INSTRUCTIONS

DCD Design & Manufacturing Ltd. SERIES 00504 DUB-IN[®] SWIVEL



INSTALLATION

1. Back off the jacking screws in the flange so that they do not protrude from the mating side of the flange.
2. Apply a bead of gasket sealant around the underside of the flange to provide a watertight seal.
3. Insert the swivel assembly into the bore of the reamer and align the bolt holes in the flange. Attach the swivel using the socket head capscrews.
4. Tighten the jacking screws down against the reamer to prevent them from vibrating loose.
5. To remove the swivel, remove the six socket head capscrews. Use the jacking screws to break the joint between the flange and the reamer.

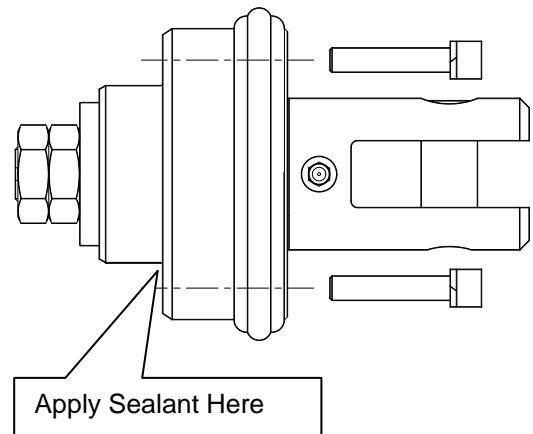

SAFETY

The DUB-IN[®] Swivel is designed to operate only within its specified safe working limit (see *Operating Specifications*). Operation of the DUB-IN[®] Swivel at loads in excess of its **safe working limit** will void the warranty as that may cause permanent bearing damage even though separation due to failure will not occur until the specified **ultimate load** is reached.



Rotating parts can cause death or serious injury! Stay well clear. Do not wear loose clothing.



Make sure that all components of the pulling system are able to withstand the maximum pulling loads. Components not rated for the pull force may break and release the stored energy of the pull. Never use a worn, defective or incomplete component.



Be prepared for the unexpected. Always use recognized safety practices and wear recognized safety equipment.



Replace worn or damaged clevis pins with only DCD parts. The Clevis Pin is designed specifically for this application. It is manufactured and heat treated in a manner to satisfy both design requirements and claimed capacities. Use of any other product as a replacement part will void the warranty and may result in property damage, severe bodily harm, or death to operators or persons nearby. In any instances, the DCD warranty will be avoided and DCD will accept no responsibility for product failure or personal injury.



Do not modify or dismantle the DUB-IN[®] Swivel. It has been assembled, and inspected and is only covered by a warranty in its "as shipped" form. Any attempt to dismantle or modify the swivel will result in the warranty becoming void.

OPERATING INSTRUCTIONS

SERVICE



After each use, while the swivel is still rotating, use a water hose to wash all dirt from the split line groove. Pour oil into the groove and rotate the swivel a couple of turns to protect the mechanical seal from drying out.



Assess the condition of the swivel checking for wear and external damage. Check for axial and radial play in the bearings. Replace worn or bent clevis pin.



Lubricate the swivel with **calcium-based grease** containing an extreme pressure (EP) additive. Use a hand-operated grease gun with slow pumping action. Lack of proper lubrication will shorten the life of the bearings.



Factory rebuild services are available for the DUB-IN® Swivel. With this service we will replace bearings, seals, and any other worn parts, as well as offer a conditional continuation on our warranty. For re-build information call the factory toll free at **1-888-794-8357**.

